

About This Manual

P/N: 4710.00447A09

Product Model: S22/S22 Exp/S22 Pro/S20 Plus/M22

Release Date: June, 2019

Copyright © 2014-2019 SonoScape Medical Corp. All rights reserved.

Statement

SonoScape Medical Corp. (hereinafter called SonoScape) owns the intellectual property rights to this manual, and also maintains the contents of this manual as confidential information. This manual is a reference for the operation, maintenance and cleaning of this product and does not convey any license under the patent rights of SonoScape, nor the rights of others.

This manual contains the information protected by copyrights or patents. Reproduction, amendment or translation of this manual in any manner whatsoever without the written permission of SonoScape is strictly prohibited.

All information contained in this manual is believed to be correct. SonoScape shall not be liable for errors contained herein or for incidental or consequential damages in connection with the furnishing, performance or use of this manual. SonoScape does not assume any liability arising out of any infringements of patents or other rights of third parties.

This manual is based on the maximum configuration and therefore some contents may not apply to your product.

This manual is subject to change without prior notice and legal obligation.

Manufacturer's Responsibility

SonoScape is responsible for the effects on safety, reliability and performance of this product, only if all the following requirements are met.



- All installation operations, expansions, changes, modifications and repairs of this product are conducted by SonoScape authorized personnel.
- The use or application of the product or the use of parts or accessories is approved by SonoScape.
- The electrical installation of the relevant room complies with the applicable national and local requirements.
- The product is used in accordance with the instructions for use.

Documentation

SonoScape provides the documentation consisting of various manuals:

- The basic user manual describes the basic functions and operating procedures of the system.
- The advanced user manual provides information about the measurements and calculations available in each mode.

Understand the meanings of the following items clearly before reading this manual.

Item	Meaning
	Indicates a potentially hazardous situation which, if not avoided, could result in death or serious injury.
	Indicates a potentially hazardous situation which, if not avoided, may result in malfunction or damage of the system.
	Indicates a potentially biological hazardous situation which, if not avoided, may result in disease transmission.
NOTE	Indicates precautions or recommendations that should be used in operating the system.

Item	Meaning
Boldfaced Word	Indicates controls on the control panel, or on-screen objects such as menu items or keys.
Click	Move the cursor to the controls on the display and press the confirm key on the control panel.
>	Select a menu item or a key following the path.

Contact Information

Manufacturer: SonoScape Medical Corp.

Address: Room 201 & 202, 12th Building, Shenzhen Software Park Phase II, 1 Keji Middle 2nd Road, Yuehai Subdistrict, Nanshan District, Shenzhen, 518057, Guangdong, China

Tel: +86-755-26722890

Fax: +86-755-26722850

E-mail: sonoscape@sonoscape.net

www.sonoscape.com

EU Representative: Shanghai International Holding Corp. GmbH (Europe)

Address: Eiffestrasse 80, 20537 Hamburg, Germany

Tel: +49-40-2513175

Fax: +49-40-255726

E-mail: shholding@hotmail.com



Contents

1	Safety	1
1.1	Intended Use	1
1.2	Safety Precautions	1
1.2.1	Electrical Safety	1
1.2.2	Mechanical Safety	2
1.2.3	Accessories Caring	3
1.2.4	Biohazard Considerations	3
1.3	Acoustic Power Principle	3
1.3.1	Biological Safety	4
1.3.2	ALARA	4
1.3.3	Mechanical and Thermal Indices	4
1.3.4	Transducer Surface Temperature Limits	5
1.3.5	Imaging Functions that Change Acoustic Output	5
1.4	Safety Symbols	5
2	System Overview	9
2.1	System Configuration	9
2.2	Physical Specifications	9
2.2.1	System Components	9
2.2.2	Peripheral Device Panel	10
2.2.3	Control Panel	11
2.2.4	Basic Screen	14
2.2.5	Touch Screen	14
3	Preparing the System	19
3.1	System Assembly	19
3.2	System Moving/Positioning	20
3.3	Connecting and Powering the System	20
3.3.1	Using the Mains Supply	20
3.3.2	Using the Battery	21
3.3.3	Indicators	21
3.4	Powering On/Off the System	22
3.4.1	Powering On the System	22
3.4.2	Powering Off the System	22
3.4.3	System Standby	22
3.5	Adjusting the System	22
3.5.1	Adjusting the Monitor Arm	22
3.5.2	Adjusting the Display Monitor	23
3.6	Connecting the Probe	24
3.6.1	Connecting the Probe	24
3.6.2	Connecting the Pencil Probe	24
3.6.3	Disconnecting the Probe	24
3.7	Connecting the Peripheral Device	24
3.7.1	Connecting the Foot Switch	24
3.7.2	Connecting the Video Printer	25

- 3.7.3 Connecting the Network Printer 25
- 3.7.4 Connecting the USB Printer..... 26
- 4 Customizing Your System..... 27**
 - 4.1 General System Settings 27
 - 4.1.1 General Settings 27
 - 4.1.2 Display Settings 29
 - 4.1.3 Storage Settings..... 30
 - 4.1.4 Defined-Key Settings 31
 - 4.2 Peripheral Device Settings 32
 - 4.3 Defining Annotation Library..... 33
 - 4.4 Body Mark Settings 34
 - 4.5 Measurement Settings..... 35
 - 4.5.1 General Measurement Settings 35
 - 4.5.2 Application Settings 36
 - 4.5.3 List Settings..... 39
 - 4.6 Touch-Screen Settings..... 40
 - 4.6.1 Adding A Parameter 40
 - 4.6.2 Modifying A Parameter 40
 - 4.6.3 Deleting A Parameter 40
 - 4.7 Report Settings 41
 - 4.8 Configuring DICOM..... 42
 - 4.8.1 Storage Service Settings..... 42
 - 4.8.2 Commitment Settings..... 43
 - 4.8.3 DICOM Worklist Settings..... 44
 - 4.8.4 MPPS (Modality Performed Procedure Step) Settings 45
 - 4.8.5 Print Service Settings 46
 - 4.8.6 QR List..... 48
 - 4.9 Defining System Defaults 49
 - 4.10 User Security..... 50
 - 4.10.1 Administrator Settings 51
 - 4.11 Viewing System Information 53
 - 4.11.1 General Information..... 53
 - 4.11.2 Acoustic Output 53
 - 4.11.3 Touch Screen Information..... 54
 - 4.12 Calibrating the Touch Screen 54
- 5 Preparing for an Exam 57**
 - 5.1 Acquiring Patient Information 57
 - 5.1.1 Beginning a New Patient..... 57
 - 5.1.2 Retrieving Archived Information 59
 - 5.1.3 Using DICOM Worklist 60
 - 5.2 Pausing/Resuming an Exam..... 60
 - 5.2.1 Pausing an Exam 60
 - 5.2.2 Resume an Exam..... 60
 - 5.3 Completing/Discontinuing an Exam..... 60
 - 5.3.1 Completing an Exam..... 60
 - 5.3.2 Discontinuing an Exam 61
- 6 Acquiring Images 63**

6.1	Selecting a Probe and an Exam Type.....	63
6.1.1	Customizing A Preset.....	63
6.1.2	To arrange the presets display.....	64
6.2	Acquiring B-Mode Images.....	65
6.2.1	Entering B Mode.....	65
6.2.2	Optimizing B-Mode Images.....	65
6.3	Acquiring Color Flow Images.....	70
6.3.1	CFM Mode.....	70
6.3.2	PDI Mode.....	70
6.3.3	TDI Mode.....	71
6.3.4	Optimizing CFM/PDI/TDI Mode Images.....	72
6.4	Acquiring M-Mode Images.....	75
6.4.1	M Mode.....	75
6.4.2	Anatomical M-Mode.....	76
6.4.3	Optimizing M-Mode Images.....	77
6.5	Acquiring Spectral Doppler Images.....	78
6.5.1	PW Mode.....	78
6.5.2	CW Mode.....	80
6.5.3	Optimizing Spectral Doppler Images.....	82
6.6	Acquiring Triplex-Mode Images.....	85
6.6.1	B+CFM/TDI +M.....	85
6.6.2	B+CFM/PDI/TDI +PW.....	86
6.6.3	B+CFM/PDI+CW.....	87
7	Elastography Imaging.....	89
7.1	Acquiring Elastography Images.....	89
7.2	Optimizing Elastography Images.....	90
7.2.1	Strain Map.....	91
7.2.2	Strain Process.....	91
7.2.3	Transparency.....	91
7.2.4	Contrast.....	91
7.2.5	Persistence.....	91
7.2.6	Frequency.....	91
7.3	Working with Elastography Images.....	92
8	Contrast Imaging.....	93
8.1	Entering Contrast Imaging.....	93
8.2	Optimizing Contrast Images.....	94
8.2.1	Gain.....	94
8.2.2	Flash Power.....	94
8.2.3	Flash Time.....	94
8.3	Acquiring Contrast Images.....	95
8.4	Working with Contrast Images.....	95
9	3D Imaging.....	97
9.1	Acquiring 3D Images.....	97
9.2	Working with 3D Images.....	99
9.2.1	Adjusting ROI.....	99
9.2.2	Setting Display Format.....	100
9.2.3	Using Auto Face.....	100

9.2.4	Setting Render Mode	100
9.2.5	Cropping Reviews.....	101
9.2.6	Moving/Rotating/Magnifying Images.....	102
9.2.7	Optimizing 3D Image.....	103
9.2.8	Observing Reference Image by the Plane	103
9.2.9	Observing Reviews by the Slice	104
9.2.10	Setting the Scan Mode	105
9.2.11	Adjusting ZAngle/ZScale	105
9.2.12	Restoring the Image	106
9.2.13	Customizing Presets	106
9.2.14	Performing Follicle Auto-Measurement	106
10	4D Imaging.....	107
10.1	Acquiring 4D Images	107
10.1.1	Entering the Real-Time 4D Imaging.....	107
10.1.2	Acquiring Dynamic 3D Image.....	109
10.2	Working with 4D Images	109
11	Working with Images	111
11.1	Imaging Features.....	111
11.1.1	Imaging Reverse	111
11.1.2	Split Screen Display.....	111
11.1.3	m-Tuning.....	112
11.1.4	Harmonic Imaging	112
11.1.5	Panoramic Imaging	113
11.2	Magnifying an Image.....	114
11.3	Freezing an Image.....	115
11.4	Using Cine.....	115
11.4.1	Reviewing Cine	115
11.4.2	Cutting Cine	115
11.5	Annotations and Body Marks	116
11.5.1	Annotating an Image.....	116
11.5.2	Body Mark	116
11.5.3	Deleting Annotations and Body Marks.....	117
11.6	Using ECG	117
11.6.1	Basic Procedures of ECG Operation.....	117
11.6.2	Optimizing Parameters.....	118
11.6.3	Reviewing ECG	118
12	Managing Images/Data.....	119
12.1	Storing an Image	119
12.1.1	Storing 2D Image	119
12.1.2	Storing 3D/4D Image.....	119
12.2	Viewing an Image	119
12.2.1	Viewing a Current Image	119
12.2.2	Retrieving an Image	120
12.3	Sharing Data.....	120
12.4	Backing up Data.....	121
12.4.1	Backing up Data to a USB drive.....	121
12.4.2	Backing up Data to DVD	121

12.5	Importing Data to the System	121
13	Working with DICOM.....	123
13.1	Verifying Connectivity.....	123
13.2	DICOM Storage	123
13.2.1	Storing the Current Image.....	123
13.2.2	Storing Patient Data	123
13.3	DICOM Print.....	124
13.3.1	Print the Current Image.....	124
13.3.2	Print Patient Data	124
13.4	DICOM Worklist.....	124
13.5	MPPS	125
13.6	Storage Commitment	126
13.7	DICOM Queue.....	127
13.8	Query/Retrieve List.....	127
14	Probes and Biopsy	129
14.1	Probe	129
14.1.1	Available Probes.....	129
14.1.2	Probe Usage	130
14.1.3	Cleaning the Probe	131
14.1.4	Disinfecting and Sterilizing the Probe	132
14.1.5	Disinfecting and Sterilizing the Probe Cable.....	134
14.1.6	Storage and Transportation	135
14.2	Biopsy	135
14.2.1	Available Biopsy Brackets.....	136
14.2.2	Assembling the Biopsy Bracket.....	137
14.2.3	Preparing for a Biopsy	139
14.2.4	Verifying the Biopsy Bracket.....	139
14.2.5	Performing a Biopsy	140
14.2.6	Cleaning the Biopsy Bracket.....	141
14.2.7	Sterilizing the Biopsy Bracket	141
14.2.8	Storage	142
15	System Maintenance	143
15.1	Cleaning the System.....	143
15.1.1	To Clean the System Surface	143
15.1.2	To Clean the Dust Filter	143
15.1.3	To Clean the Trackball	143
15.2	Maintenance Checks	144
15.3	Troubleshooting	144
15.4	Replacing the Fuse.....	145
15.5	Equipment Disposal.....	145
15.6	Customer Service.....	145
Appendix A	Specifications.....	146
Appendix B	EMC Guidance and Manufacturer’s Declaration.....	147
B.1	Electromagnetic Emissions.....	147
B.2	Electromagnetic Immunity.....	147

B.3 Recommended Separation Distances between Portable and Mobile RF Communications Equipment and the Equipment.....	150
Appendix C In Situ, Derated, and Water Value Intensities	151
Appendix D Recommended Coupling Gel, Cleaner and Disinfectant	152
D.1 Coupling Gel.....	152
D.2 Cleaner	153
D.3 Disinfectant.....	153
Appendix E Acoustic Output Data	154

1 Safety

This chapter describes the important information for operating this ultrasound system. To ensure the safety of both operator and patient, please read the relevant details in this chapter carefully before using this system.

You should be thoroughly familiar with the precautions provided in this manual. Otherwise, the manufacturer is not responsible for the effects on safety, reliability and performance of the system.

1.1 Intended Use

The system is a general-purpose ultrasonic imaging instrument intended for use by a qualified physician for evaluation of Fetal, Abdominal, Pediatric, Small Organ (breast, testes, thyroid), Cephalic (neonatal and adult), Trans-rectal, Trans-vaginal, Peripheral Vascular, Cerebral Vascular, Musculo-skeletal (Conventional and Superficial), Cardiac (pediatric and adult), Trans-esoph.(Cardiac), Laparoscopic, OB/Gyn and Urology.

The system also provides the measurement and calculation packages used for clinical diagnosis purposes. For details, please refer to the advanced user manual.

Contraindication: The system is not intended for ophthalmic use or any use causing the acoustic beam to pass through the eye.



WARNING Precautions must be considered in the use of any application. Otherwise, it may result in system damage or serious injury.

1.2 Safety Precautions

Read and understand all precautions in this manual before attempting to use the system. Keep this manual with the system at all times. Review the procedures for operation and safety precautions periodically.

1.2.1 Electrical Safety



- Any unauthorized personnel should not tamper with the main unit of the system.
- Do not service or maintain the system while it is in use with a patient.
- Do not position the system to make it difficult to disconnect the system from the mains supply.
- Do not use the system with flammable anaesthetics (category AP) or flammable anaesthetics with oxidants (category APG).
- Do not use the system with other equipment such as an electric knife, high-frequency therapy equipment, or a defibrillator. Otherwise, electrical shock may occur.
- Connect the protective earth conductor only before powering on the system. Disconnect the ground wire only after powering off the system. Otherwise, electrical shock may occur.
- Connect the system to the other electrical equipment by using the potential-equalization lead wire before connecting the power plug of the system to an electrical outlet.
- Do not place the multiple socket-outlet on the floor.
- The video printer should be connected to the specific interface by using the cable provided by the manufacturer. Otherwise, electrical shock may occur.

- Within the environment that is 1.8 meters (6 feet) around a patient, connect peripherals to the auxiliary power outlet which is capable of isolation protection; or, power the peripherals by the auxiliary output cable or the isolation transformer complied with EN/IEC 60601-1, or the power input of the same safety level.
- Within the patient environment, when removing the covers or the connectors from the non-medical electrical equipment without tools during maintenance, calibration or other operations, do not touch the parts of the non-medical electrical equipment and the patient simultaneously.
- Use only the probes provided by the manufacturer. Otherwise, the system will not perform, and an accident such as a fire may result in the worst case.
- Only the peripherals and accessories provided or recommended by the manufacturer can be used. Using other devices or accessories may degrade the system performance and even cause electrical shock.
- Do not pour any fluid onto the system surfaces, as fluid seepage into the electrical circuitry may cause excessive electrical current leakage or system failure. If any water is spilled onto the system carelessly, stop using the system and contact the local distributor immediately.
- The AC power plug for the system is a three-prong grounded plug and should never be adapted to any two-prong outlet or by using an adapter. Connect the AC power plug of the multiple socket-outlet to a hospital-grade power outlet.



- If the system is transported to the operating environment with a great temperature change, leave it for approximately 4 hours before powering it on. Ensure that the temperature and humidity inside and around the system are equivalent before an operation.
- Only qualified physicians or sonographers can perform ultrasound scanning on human subjects for medical diagnostic reasons.
- Do not use the system around a strong electric field, a strong electromagnetic field, or the devices which generate radio waves, such as a radio, cellular telephones, or transceivers. Using the system in an improper environment may result in malfunction or damage.
- Select the conformed multiple socket-outlet with protective grounding, and ensure that its maximum output power exceeds the requirement of the system.
- The multiple socket-outlet can only be used to provide power to the recommended peripherals of the system.
- Do not connect other devices to the multiple socket-outlet. Otherwise, the rated output power of the multiple socket-outlet may be exceeded, and it may result in failure.
- Accessory equipment connected to the analog and digital interfaces must be certified according to the respective EN/IEC standards (for example, EN/IEC 60950 for data processing equipment and EN/IEC 60601-1 for medical equipment). Furthermore, all configurations shall comply with the system standards EN/IEC 60601-1.
- Do not use an endocavitary probe on the body surface of a patient. Otherwise, the electromagnetic compatibility of the probe may be degraded.
- If the non-medical electrical equipment used with the system is supplied by a multiple socket-outlet with separating transformer, connect the AC power plug of the multiple socket-outlet to a hospital-grade power outlet. Consult a professional to ensure that the connection complies with the safety standards.

1.2.2 Mechanical Safety



- To avoid possible personnel injury and system damage, move the system slowly and carefully.
- During the movement, the system could cause injury if the casters roll over feet or into shins. Exercise extreme caution while moving the system for a long distance, and up or down the ramp.
- Lock the foot brakes after arrival.



- Do not place other objects on top of the control panel. Do not sit on the control panel or any other part of the system.

- Disconnect the foot switch and the power cable before moving the system.
- Do not knock or shake the system.
- Ensure that the casters are intact and can rotate well before moving the system.
- Always use the handle to move the system.
- Ensure that the foot brakes are released and all cables are away from the casters before moving the system.

1.2.3 Accessories Caring



- Do not use the foot switch in the operating room.
- Use the probe carefully. If any part of the transducer surface is scratched, stop using the probe immediately. Otherwise, electrical shock may occur.
- After disinfecting the accessories, wash out chemicals or discharge gases thoroughly from the accessories. Residual chemicals or gases could result in damage to the accessories, and be harmful to human bodies.
- Only trained physicians or sonographers under ultrasound guidance can handle the biopsy needle guides. During the operation, the operator must observe proper needle insertion sequencing with the needle guide to avoid undue discomforts, unnecessary risks or injuries to the patient.
- Use the legally marketed probe sheath. Refer to package labeling to determine latex content. Natural rubber latex may cause anaphylactic reactions in some individuals. Avoid contact with items containing natural rubber latex. Refer to the FDA Medical Alert, March 29, 1991.
- Use the legally marketed coupling gel in accordance with relevant local regulations. Read and understand all precautions in the relevant manual of the coupling gel before use.
- Prepare, use, store and dispose the cleaner, disinfectant and sterilant according to the instructions provided by manufacturers.



- Do not disconnect the probe during the real-time scan. Otherwise, it may damage the probe and the system.
- Disconnect the probe from the system after freezing an image or powering off the system. Otherwise, the system or the probe could be damaged.

1.2.4 Biohazard Considerations



- To minimize the risk of cross-contamination or infectious diseases when performing a biopsy, the operator should wear disposable gloves, protective clothing or protective goggles if it is needed. Follow the working regulations strictly in case the skin contacts the samples.
- Some disinfectants or sterilants are acid or alkaline. Use them with caution, and prevent hands or clothing from coming into direct contact with them. Wash hands or eyes immediately in case of any contamination by disinfectants.
- Dispose of cleaners, disinfectants or solutions in accordance with local standards or regulations.

1.3 Acoustic Power Principle



- Perform ultrasound procedures prudently under the guidance of the ALARA (as low as reasonably achievable) principle. Only expose the patient to the lowest practical transmit power levels in the shortest possible period to achieve a satisfactory diagnosis.
- Freeze the image at any time if you are not operating the system for a long period of time.
- Do not scan the same part of an patient continuously or expose the patient to prolonged scanning. Doing so may harm the patient.
- Do not expose the fetus to prolonged scanning in the Doppler mode.
- Although the output power is automatically controlled for the selected applications, high TI values should be kept to a minimum or avoided in obstetric applications.

- You should be familiar with the performances and operations of the system, observe the ultrasound output parameters on the screen at all times.

1.3.1 Biological Safety

Diagnostic ultrasound is recognized as being safe, but the possibility of biological effects exists when using it in high exposure levels and long exposure times. Thus ultrasound should be used in a prudent manner to provide medical benefit to the patient.

1.3.2 ALARA

It is required to practice ALARA when using ultrasound energy. Practicing ALARA ensures that the total energy level is controlled below a low enough level at which bioeffects are not generated while diagnostic information is being accumulated. The total energy is controlled by output intensity and total radiation time. The output intensity necessary for examinations differs depending on the patient and the clinical case.

Not all examinations can be performed with an extremely low level of acoustic energy. Controlling the acoustic level at an extremely low level leads to low-quality images or insufficient Doppler signals, adversely affecting the reliability of the diagnosis. However, increasing the acoustic power more than necessary does not always contribute to an increase in quality of information required for diagnosis, rather increasing the risk of generating bioeffects.

The operator must take responsibility for the safety of the patient and utilize the ultrasound deliberately. Deliberate use of the ultrasound means that output power of the ultrasound must be selected based on ALARA. Additional information regarding the concept of ALARA and the possible bioeffects of Ultrasound is available in a document from the AIUM (American Institute of Ultrasound Medicine) title “Medical Ultrasound Safety”.

1.3.3 Mechanical and Thermal Indices

The display of the system consists of two parts: Thermal Index (TI) and Mechanical Index (MI).

■ MI/TI Explanation

In October 1987, the American Institute of Ultrasound in Medicine (AIUM) ratified a report prepared by its Bioeffects Committee (Bioeffects Considerations for the Safety of Diagnostic Ultrasound, J Ultrasound Med., Sept. 1988: Vol. 7, No. 9 Supplement), sometimes referred to as the StoweReport, which reviewed available data on possible effects of ultrasound exposure. Another report “Bioeffects and Safety of Diagnostic Ultrasound” dated January 28, 1993, provides more current information.

- Mechanical Index (MI)

Mechanical bioeffects are threshold phenomena that occur when a certain level of output is exceeded. The threshold level varies, however, with different types of tissue. The potential mechanical bioeffects varies with peak pressure and ultrasound frequency. The MI accounts for these two factors. The higher the MI value, the greater the likelihood of mechanical bioeffects occurring. There is no specific MI value that means that a mechanical effect is actually occurring. The MI should be used as a guide for implementing the ALARA principle.

- Thermal Index (TI)

The TI value informs the operator about the conditions that might lead to an increase in temperature on the surface of the body, within the body tissue, or at the point of focus of the ultrasound beam on bone. That is, the TI value informs the operator about the potential temperature rise in body tissue. It is an estimate of temperature increase in body tissue with specific properties. The actual amount of any temperature rise is influenced by factors such as tissue type, vascularity, mode of operation and others. The TI value should be used as a guide for implementing the ALARA principle.

Depending on the examination and type of tissue involved, TI could be one of three types:

- Soft Tissue Thermal Index (TIS) is used when imaging soft tissue only, it provides an estimate of potential temperature rise in soft tissue.
- Bone Thermal Index (TIB) is used when bone is near the focus of the image as in the third trimester, it provides an estimate of potential temperature rise in the bone or adjacent soft tissue.

- Cranial Bone Thermal Index (TIC) is used when bone is near the skin surface as in transcranial examination, it provides an estimate of potential temperature rise in the bone or adjacent soft tissue.

■ MI/TI Display

TI and MI values are displayed in real time on the screen. The operator should observe these index values during examinations and ensure that exposure time and output values are maintained at the minimum amounts needed for effective diagnosis.

The MI and TI precision is 0.1.

1.3.4 Transducer Surface Temperature Limits

For probes intended for internal applications, e.g. the endocavitary or transesophageal probes, the surface temperature of the probe may change by adjusting system parameters.

The maximum surface temperature of the endocavitary probes is 43°C. To protect the patient against the harm of excessive temperature, the probe stops working automatically when its temperature reaches the limit. The surface temperature of the probe is displayed on the screen.

PAT: 37.0°C	— Patient Threshold Temperature
TIP: < 28°C	— Transducer Tip Temperature







1.3.5 Imaging Functions that Change Acoustic Output

















The qualified operator may use the system controls to limit the ultrasound output and to adjust the quality of the images. The operator should observe the acoustic output display for possible effects.





There are three categories of system controls relative to output. They are controls that have direct effect on the output, controls that indirectly control output and controls that are receiver controls.

1.4 Safety Symbols

The following table is provided for your identification of important symbols located in labels on the system.

Symbol	Meaning
	Caution
	Dangerous voltage
	Pinch hazard
	Risk of explosion if used in the presence of flammable anesthetics
	This product is provided with a CE marking in accordance with the regulations stated in Council Directive 93/42/EEC.
	Authorized representative in the European community

Symbol	Meaning
	Type BF applied part
	Main switch OFF
	Main switch ON
	On/Standby switch
	Foot switch connector
	Protective earth (ground)
	Equipotentiality
	Alternating current
IPN₁N₂	Degree of IP protection
	Non-ionizing electromagnetic radiation
	Manufacturer
	Date of manufacture
	Follow instructions for use
	Network port
	USB port
	Fragile
	Keep dry
	No stacking

Symbol	Meaning
	Maximum stacking limit of packages Maximum of two layers allowed for the monitor
	Keep this way upward
	Serial number
	Rechargeable (for battery only)
	This symbol indicates that waste electrical and electronic equipment must not be disposed of as unsorted municipal waste and must be collected separately. Please contact an authorized representative of the manufacturer for information concerning the decommissioning of your equipment.

This page is intentionally left blank.

2 System Overview

This ultrasound system adopts advanced ultrasonic Doppler technologies.

To ensure the performance and availability of this ultrasound system, you should be thoroughly familiar with the operations of system components, the control panel, the key panel and the basic screen.

2.1 System Configuration

The standard system configuration mainly consists of the following items:

- Main unit
- Probes
- Others: See the Packing List in the packaging box.

2.2 Physical Specifications

- System dimensions: approx. 726mm(W)×1389mm(H)×559mm(D)
- System weight: approx. 60kg

2.2.1 System Components

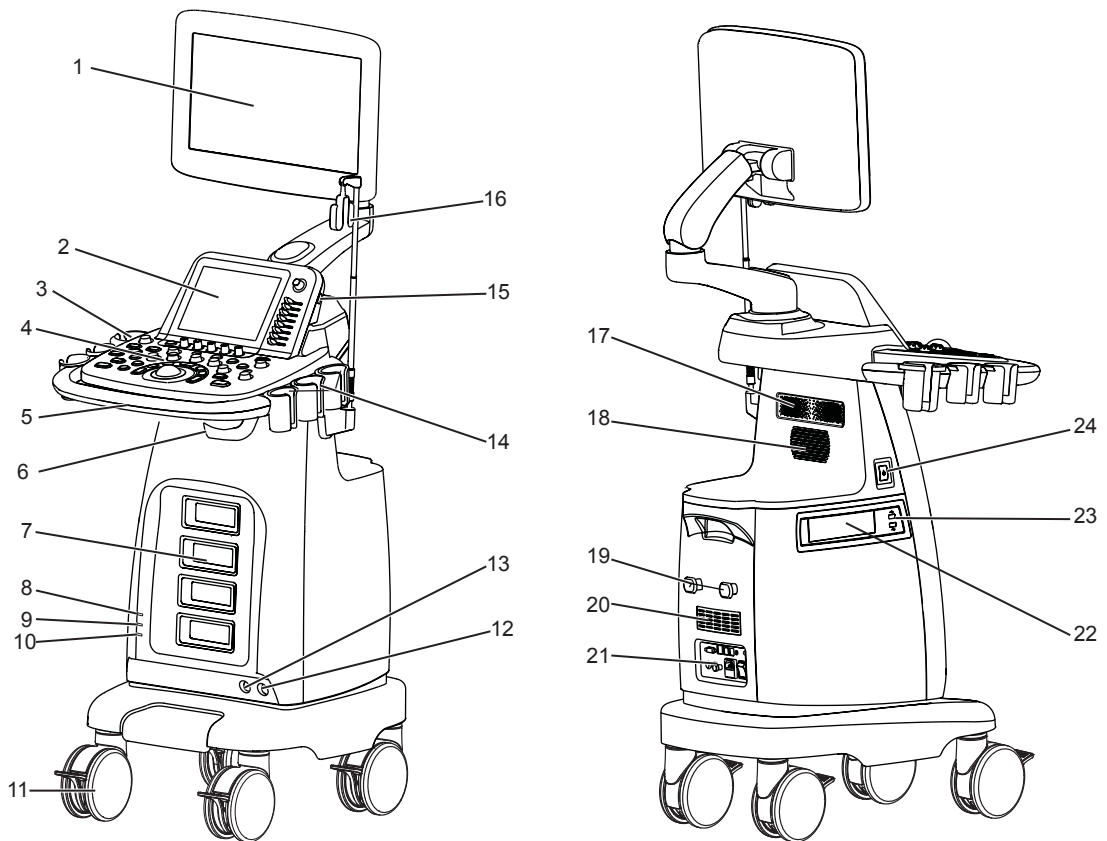

Figure 2-1 System Overview

- | | |
|----------------------------------|----------------------------|
| 1 LCD Monitor | 13 Pencil Probe Port |
| 2 Touch Screen | 14 Probe Holder |
| 3 Coupling Gel Holder | 15 Engineering USB Port |
| 4 Control Panel | 16 Cable Hanger |
| 5 Front Panel | 17 Speaker |
| 6 Transducer Cable Hanger | 18 Fan |
| 7 Probe Port | 19 Cable Hanger |
| 8 Power Indicator | 20 Dust Filter |
| 9 Charging/Discharging Indicator | 21 Peripheral Device Panel |
| 10 Battery Capacity Indicator | 22 DVD Drive (optional) |
| 11 Caster | 23 USB Port |
| 12 Foot switch Port | 24 On/Standby Button |

2.2.2 Peripheral Device Panel

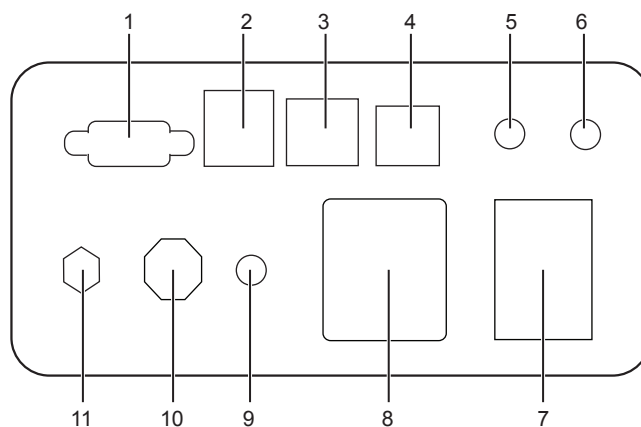

Figure 2-2 Peripheral Device Panel

No.	Name	Description
1	VGA Video Output	Used for connecting a video device to acquire VGA signals, such as monitor or projector.
2	USB Port	Used for connecting the USB devices.
3	Network Port	Used for connecting the DICOM server or the network.
4	S-VIDEO Port	Used for connecting a video device to acquire S-VIDEO signals, such as monitor or projector.
5	Audio Signal Output	Used for connecting an audio device.
6	Video Printer Port	Used for connecting the video printer.
7	Mains Supply Switch	Used for powering on or off the system.
8	Power Input	Used for connecting the power cable.
9	Equipotential Terminal	Used for equipotential connection, balancing the protective earth potentials between the system and other electrical equipment.

No.	Name	Description
10	ECG Port (optional)	Used for connecting the ECG cable.
11	Video Output	Used for connecting a video device to acquire compound signals, such as video printer.

2.2.3 Control Panel

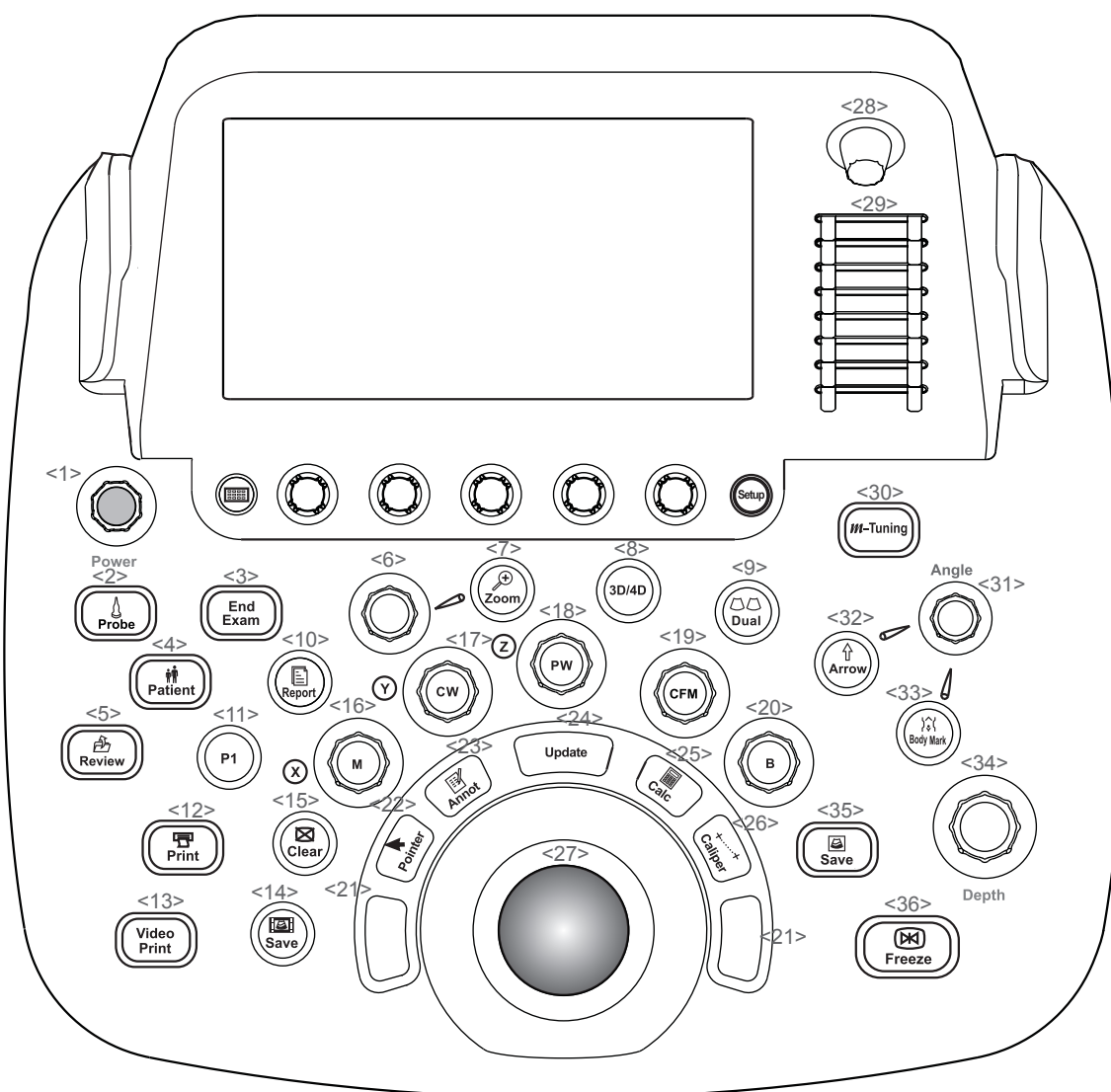

Figure 2-3 Control Panel

No.	Name	Description
<1>	Power	Rotate it to adjust the ultrasound acoustic power.
<2>	Probe	Press it to select a probe and an icon for the corresponding exam type.
<3>	End Exam	Press it to end the exam for the current patient in the real time mode.
<4>	Patient	Press it to enter the New Patient screen.
<5>	Review	Press it to display the Patient Exam List screen. Or, press it to enter the Review Image screen when creating a new patient exam.

No.	Name	Description
<6>	Scale Knob	Rotate it to adjust the image when activating the zoom feature.
<7>	Zoom	Press it to activate the zoom feature.
<8>	3D/4D	Press it to enter or exit the 3D/4D mode.
<9>	Dual	Press it to enter the dual split display. Or, press it to activate the desired image in the dual split display.
<10>	Report	Press it to enter the Report screen.
<11>	P1	Press it to save images, cine or volume data. For details, refer to Section 4.1.4 Defined-Key Settings.
<12>	Print	Press it to trigger the network printer if the network printer is successfully connected.
<13>	Video Print	Press it to print the current screenshot if the video printer is successfully connected.
<14>	Save	Press it to save cine in the frozen mode.
<15>	Clear	Press it to remove all measurement results, annotations and body mark symbols from the display.
<16>	M	Press it to enter the inactivated M mode. Or, rotate it to adjust the gain value in the M mode.
<17>	CW	Press it to enter the inactivated CW mode. Or, rotate it to adjust the gain value in the CW mode.
<18>	PW	Press it to enter the inactivated PW mode. Or, rotate it to adjust the gain value in the PW mode.
<19>	CFM	Press it to enter the CFM mode. Or, rotate it to adjust the gain value in the CFM mode. In 3D/4D mode, rotate it to move the 3D image horizontally.
<20>	B	Press it to enter the B mode. Or, rotate it to adjust the gain value in the B mode.
<21>	Confirm Key	Defined as the confirm key. Press it to confirm the current operation.
<22>	Pointer	Press it to activate the clipboard in the 2D (B/CFM/PDI/TDI)/M mode. Or, press it to activate the cursor in the 3D/4D mode.
<23>	Annot	Press it to annotate an image with typed words.
<24>	Update	<ul style="list-style-type: none"> ● Press it to enter the M/PW/CW mode in inactivated M/PW/CW mode. ● Press it to switch between measurement markers when performing the distance or ellipse measurement. ● Press it to undo the trace when performing a trace measurement.
<25>	Calc	Press to activate the application-specific measurement and calculation features.

No.	Name	Description
<26>	Caliper	Press to activate the basic measurement and calculation features. <ul style="list-style-type: none"> • Press it to perform the distance measurement in the 2D (B/CFM/PDI/TDI)/M/3D/4D mode. • Or, press it to activate the velocity measurement in the PW/CW mode.
<27>	Trackball	Use it to move the cursor and adjust ROI.
<28>	-Audio+	Rotate it to adjust the volume.
<29>	TGC	Use these sliders to adjust the TGC settings at different scan depth.
<30>	m-tuning	Press it to optimize an image automatically.
<31>	Angle	<ul style="list-style-type: none"> • Rotate it to adjust the flow direction in the PW/CW mode. • Rotate it to adjust the angle of M line in the M mode. • Rotate it to adjust the arrow direction if the arrow annotation feature is activated. • Rotate it to adjust the probe direction if the body mark feature is activated. • Rotate it to adjust the angle of hip joint when performing the pediatrics measurement.
<32>	Arrow	Press it to add arrows on an image.
<33>	Body Mark	Press it to add body marks on an image.
<34>	Depth	Rotate it to adjust the scan depth.
<35>	Save	<ul style="list-style-type: none"> • In the real-time mode or frozen mode, press it to save an image. • In the real-time contrast imaging mode, press it to set the start frame for a cine of blood flow, and press it again to set the end frame.
<36>	Freeze	Press it to freeze an image in the real time mode. Or, press it again to restore the real time scan.

2.2.4 Basic Screen

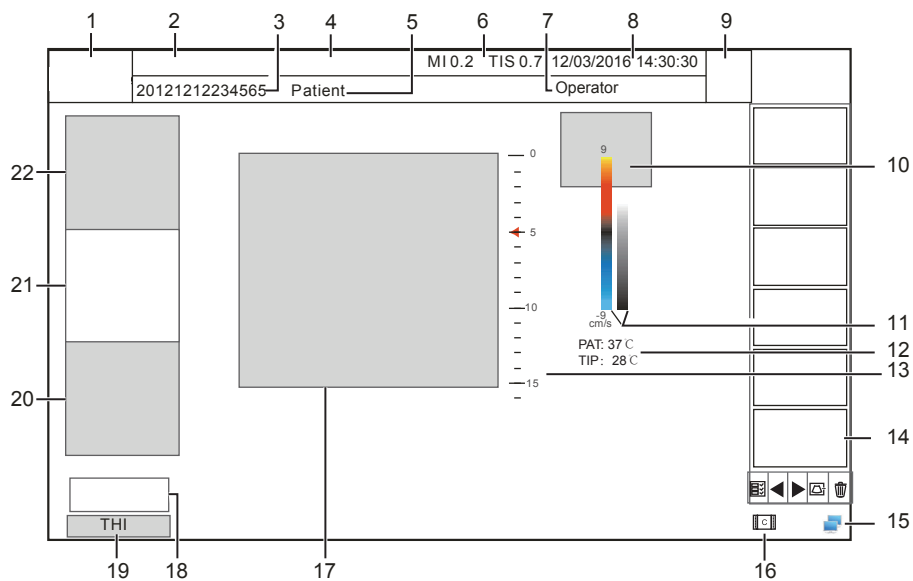

Figure 2-4 Basic Screen

- | | |
|--|--|
| 1 Logo | 13 Depth Scale and Focal Position |
| 2 Institution Name | 14 Clipboard |
| 3 Patient ID | 15 Network Connection Status |
| 4 Probe Model/Exam Type | 16 Cine Loop Icon (in frozen mode) |
| 5 Patient Name | 17 Imaging Area |
| 6 MI and TIS Indices | 18 Cine Loop Status (in frozen mode) |
| 7 System Date and Time | 19 THI and PW/CW Status |
| 8 Exam Type Icon | 20 PW/CW/M Mode Imaging Information |
| 9 Operator | 21 Color Flow Mode Imaging Information |
| 10 Measurement Result Area | 22 B-Mode Imaging Information |
| 11 Color Map (in Color/PDI mode) / Grayscale Map (Right) | |
| 12 Temperature Display Area | |

2.2.5 Touch Screen

The touch screen above the control panel provides controls which can be used to select the probe model in accordance with the exam type, annotate the image or perform the measurement. The touch screen contains several types of controls, depending on the feature to be performed.

NOTE:

A same effort can be achieved by using controls on the touch screen or controls and knobs located on the control panel and the key panel if they are of the same name. In such condition, only the system operated with the touch screen is described in this manual.

 **CAUTION** To avoid damaging the touch screen,

- Do not expose it in direct sunlight.
- Tap it gently with fingers.
- Do not operate it with a sharp or hard object.
- Do not locate it in environmental temperature of sudden changes.
- Do not locate it near static electricity or high voltage.
- Keep the screen clean without any adhesive tapes.

Controls located on the touch screen are displayed as follows:

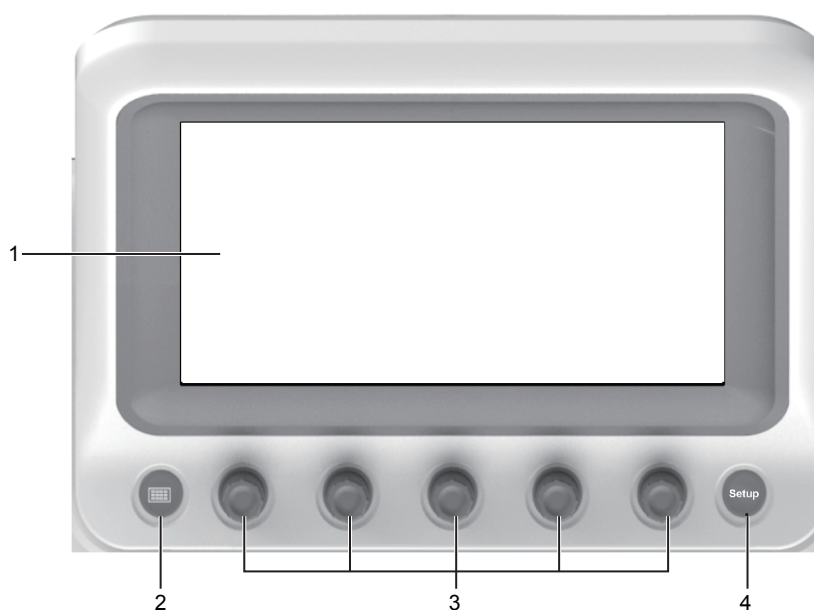

Figure 2-5 Touch Screen

No.	Name	Description
1	Touch Screen	The display varies with the feature to be performed.
2	Key-Panel Key	Press it to activate the key panel of the touch screen. Or, press it again to return to the previously operating screen.
3	Image Optimization Knob	Rotate the knob that is directly below the desired item to adjust the value when optimizing the image. Generally, rotating it clockwise can enable the feature or increase the value of the corresponding parameter; rotating it anticlockwise can disable the feature or decrease the value of the corresponding parameter.
4	Setup Key	Press it to enter the System Setting menu.

■ Application Mode Screen

The application mode screen (as shown below) is used to select the probe model or exam type.

The system enters the following screen by default once it is started up. Press the **Probe** key on the control panel to return to the following screen when you enter other screens.



Figure 2-6 Application Mode Screen

■ **Imaging Mode Menu**

The imaging mode menu (as shown below) is used to select the imaging mode, optimize the image or adjust parameters. Select an exam type from the application mode screen to enter the following screen.

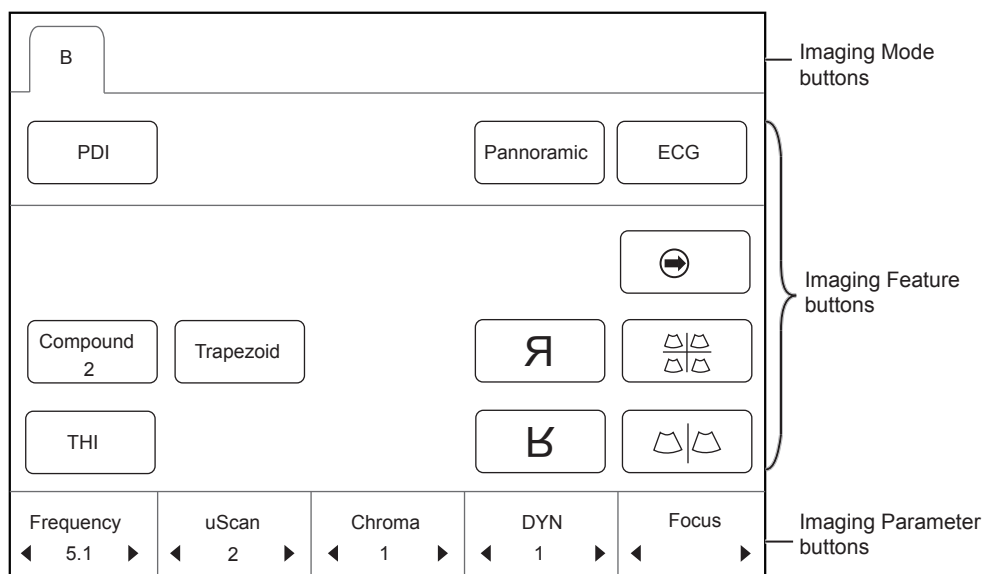

Figure 2-7 Imaging Mode Menu

■ **Annotation/Body Mark Menu**

The annotation/body mark menu is used to select an annotation or body mark. Press the **Annot** or **Body Mark** button on the control panel to enter the corresponding screen. Take the body mark menu as an example, the screen is shown as below.

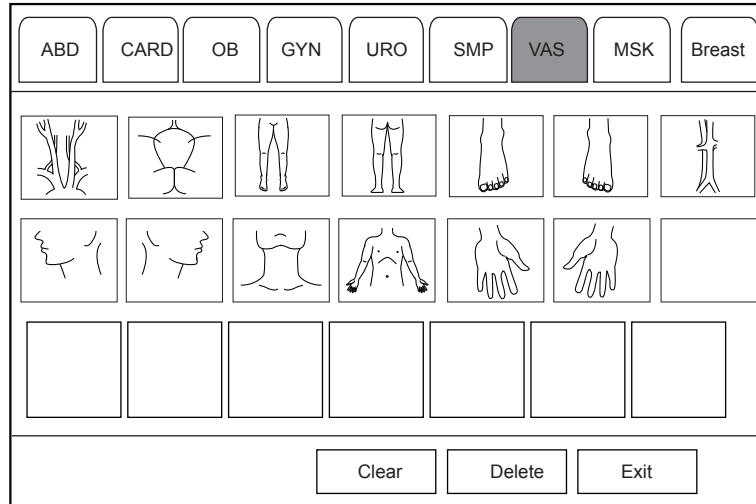

Figure 2-8 Body Mark Menu

■ **Measurement Menu**

The measurement menu is used to select the measurement item to be performed.

Press the **Caliper** key on the control panel to enter the basic measurement menu. Or, press the **Calc** key on the control panel to the application-specific measurement menu.

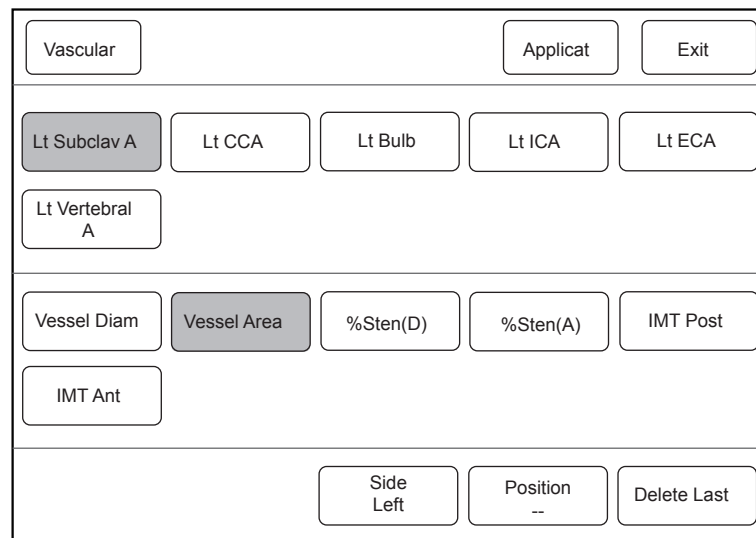



Figure 2-9 Measurement Menu

■ **Key Panel of Touch Screen**

The key panel of the touch screen (as shown below) is used to enter the text, such as the patient information. Press  on the control panel to enter the following screen.

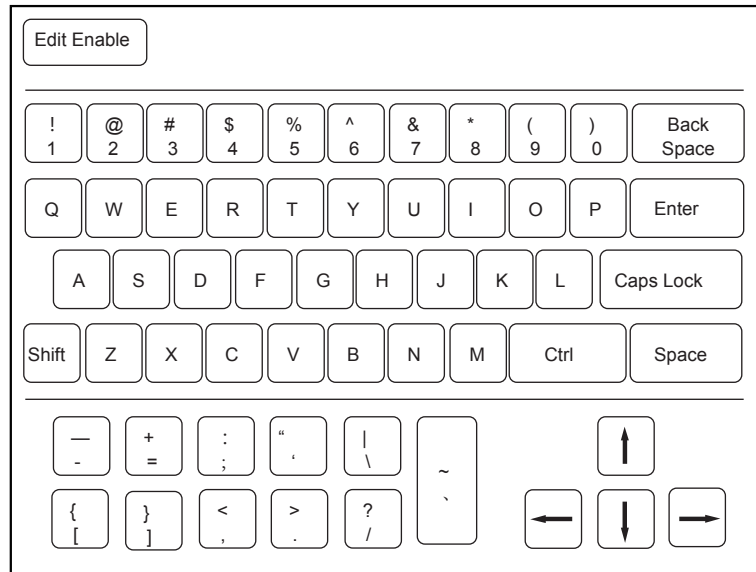

Figure 2-10 Key Panel of Touch Screen

3 Preparing the System

System preparation is necessary performed before using the system. The preparation includes but is not limited to moving, positioning or adjusting the system, connecting the probe and the peripheral devices..

3.1 System Assembly



WARNING Only service personnel authorized by the manufacturer can assemble the system. Ensure the system is firmly assembled before it is powered on.

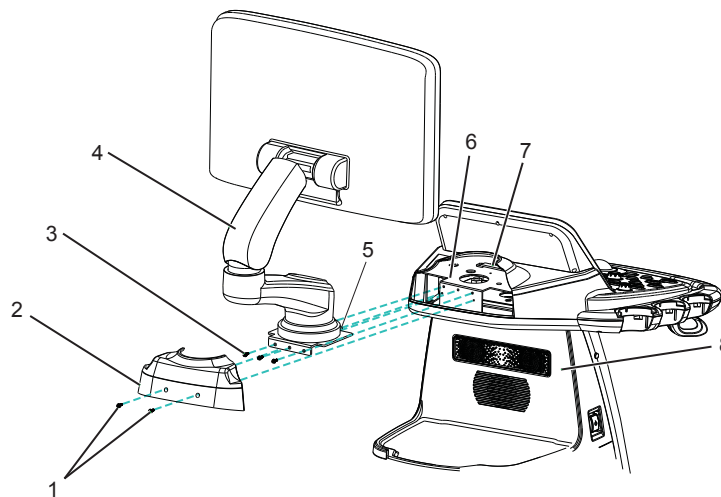

Figure 3-1 System Assembly

- | | | | |
|---|--------------------------|---|----------------|
| 1 | M3×8 Screws | 5 | 8 Main Unit |
| 2 | Control Panel Back Cover | 6 | Fixing Board |
| 3 | M4×10 Screws | 7 | Cable Trough |
| 4 | Monitor Arm | 8 | Fixing Bracket |

Perform the following steps to assemble the system.

1. Take out the back cover of the control panel by removing two M3×8 screws with a cross screwdriver.
2. Remove M4×10 screws from monitor arm by using a cross screwdriver.
3. Place the fixing board on the fixing bracket, and fix it by using three M4×10 screws.
4. Plug VGA signal cable and power supply cable into corresponding sockets on the fixing bracket.
5. Install the back cover of the control panel by fastening two M3×8 screws.

3.2 System Moving/Positioning



Leave at least 20cm at the back and both sides of the system for ventilation. Otherwise, the temperature rise could cause failures.

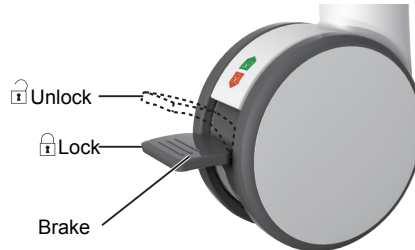

Perform the following steps to position the system.

1. Unlock the four foot brakes.
2. Move the system with the handle.
3. Lock the four foot brakes after placing it in the desired location.

3.3 Connecting and Powering the System

Two methods can be used to supply power for the system: mains supply and built-in rechargeable lithium battery. When the adapter is connected to the mains supply, the battery is charged until it is full.

3.3.1 Using the Mains Supply

Two switches are provided for the system.

- The power switch located on the peripheral device panel is used to connect or disconnect the system with the mains supply.
- The  key on the side panel is used to start up or shut down the system.



- Ensure the system works with the required voltage before you connect it to the mains supply. For details, refer to Appendix A Specifications.
- Do not pull the power cable forcibly.

To connect the system:

1. Connect the power grounding cable to the grounding terminal.
2. Connect the power cable to the mains power socket on the peripheral device panel of the system.
3. Set the power switch on the peripheral device panel to the  position.

3.3.2 Using the Battery



- Do not disassemble or alter the battery. Otherwise, there is a danger of explosion.
- Replace the battery with the same or the equivalent type.
- Do not short-circuit the battery by directly connecting the system with metal objects.
- If the battery emits an odor or heat, is deformed or discolored, or appears abnormal during use, charging or storage, remove it and stop using it immediately. If you have any questions about the battery, please contact the manufacturer.
- Do not use a battery if it leaks. If your skin or clothing is stained with the fluid from the battery, thoroughly wash the area immediately with clean water. If the fluid comes into contact with your eyes, immediately flush your eyes with water and seek an oculist for help.
- If the battery is found damaged, severely degraded or used for 3 years, dispose of it in accordance with the local laws or regulations.

The battery is automatically charged when the system is connected to the mains supply through a power supply cable.

If the system is disconnected from the mains supply, the system is automatically powered by the battery.

- A fully charged battery can work continuously for more than one hour.
- Two batteries are used for system power supply, they must satisfy the following specifications,
 - Nominal voltage: 14.8V
 - Battery capacity: 9.6Ah/142Wh
 - Limited charging voltage: 16.8V
 - Charging temperature range: 0°C~ 45°C
 - Discharging temperature range: -20°C~ 60°C





- Use only the battery when there is an emergency or no reliable mains supply is available. You are always recommended to use the AC supply instead of the battery to guarantee the battery life.
- Charge the battery in an area with a temperature range from 0°C~ 45°C and discharge it in an area with a temperature range from 0°C~ 60°C to maintain the lifespan of the battery.
- Always charge the battery to full to maintain the lifespan of the battery.
- When the battery capacity is low and the battery cannot be charged in time, you need to save all unsaved data before the system automatically shuts down. Otherwise, you may lose useful information.
- To avoid the battery damage causing the system damage, observe the following precautions:
 - Do not immerse the battery in water or allow it to get wet.
 - Do not discard the battery in a fire.
 - Do not leave the battery in direct sunlight or expose it to temperature over 60°C (140 °F).
 - Keep the battery away from fire and other heat sources during use and charge.
 - Do not place the battery into a microwave oven or other pressure vessels.
 - Do not pierce the battery with a sharp object, hit it, or step on it.

3.3.3 Indicators

The status of indicators is shown in Table 3-1.

Table 3-1 Indicator Descriptions

Status Indicator	Mains Supply	Battery Supply
 Battery Charging Indicator	Yellow, charging	Off
	Green, fully charged	



Status Indicator	Mains Supply	Battery Supply
 Mains Supply Indicator	Green	Off
 Battery Discharging Indicator	Off	Green, full capacity Yellow, low capacity Blinking yellow, extremely low capacity, the system automatically shuts down and the buzzer beeps.

3.4 Powering On/Off the System





- Do not power off the system during a system upgrade or a data transmission.
- An extra 30-60 seconds are needed for powering on the system if it is powered off in an abnormal way previously.
- If the system is configured with the μ Scan feature, do not connect the USB device to the system before system startup.
- Wait approximately 20 seconds before powering on the system again after powering it off. Otherwise, a failure may result.
- Do not unplug the system from the AC power outlet before the shutdown hint disappears. Otherwise, the data may be lost or corrupted.
- To maintain the safety and functionality of the system, maintenance must be performed at least once every year. For details, refer to 15 System Maintenance.

3.4.1 Powering On the System

1. Set the power switch on the rear panel to the  position.
2. Press the  key on the side panel to power on the system.

All operating indicators illuminates, the initial screen and the application mode screen appear after the system completes the initialization.

3.4.2 Powering Off the System

1. Press the  key on the side panel to power off the system.
2. Set the power switch on the rear panel to the  position.

3.4.3 System Standby

If the system is idle for a set period, the screen saver will be activated. For details, refer to Section 4.1.1 General Settings.

3.5 Adjusting the System

3.5.1 Adjusting the Monitor Arm

NOTE:

- Be careful with your fingers when adjusting the monitor arm.
- Lock four casters before you adjust the monitor arm.

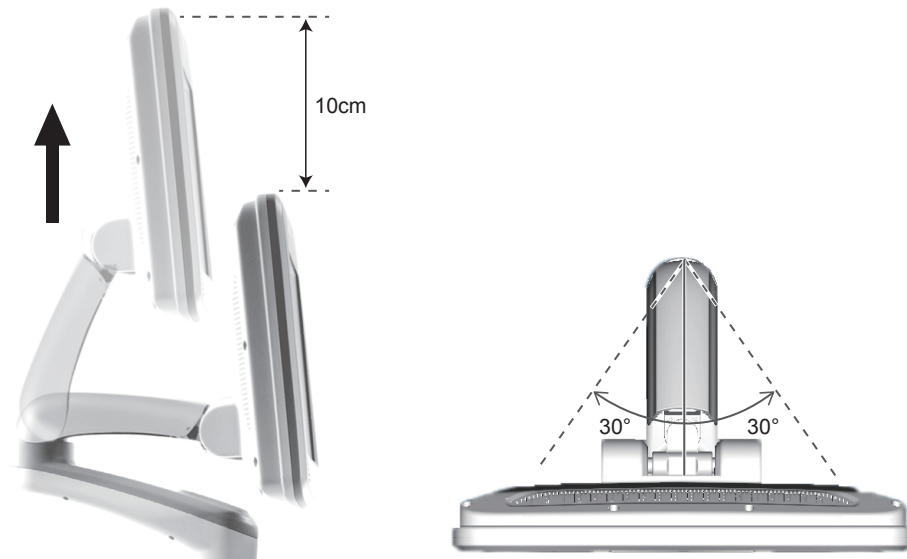

- To adjust the monitor vertically, move the upper arm towards to or backwards from the lower arm.
- To adjust the monitor horizontally, swivel the upper arm left or right.

3.5.2 Adjusting the Display Monitor

■ To swivel the LCD monitor

Grip the upper and lower sides of the monitor, tilt the monitor forward or backward.

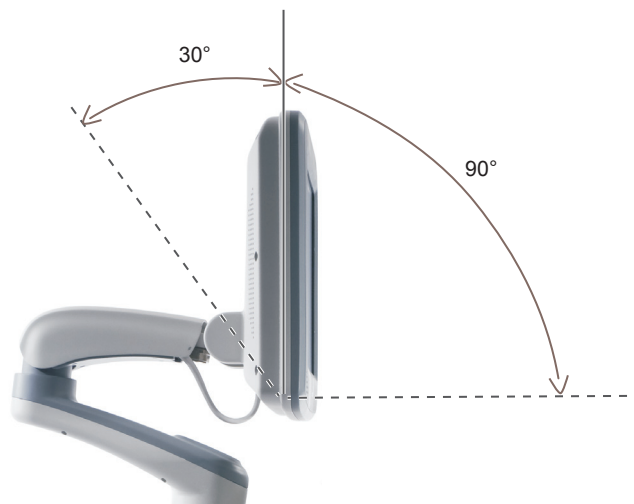

Grip the left and right sides of the monitor, swivel the monitor left or right.

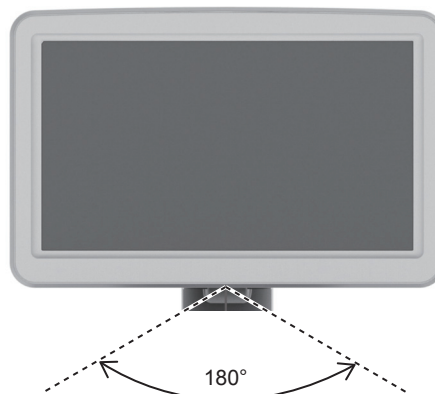

■ **To adjust the brightness and contrast**

Adjusting the LCD monitor’s brightness and contrast is one of the most important factors for obtaining the optimum image.

The proper setup displays a complete gray scale. The lowest level of black should just disappear into the background and the highest white should be bright, but not saturated.

Use the buttons located on the bottom of the monitor to adjust the brightness and contrast settings of the monitor.

- Press **Enter** to enter the monitor menu.
- Press **Enter**, press – or to + highlight **Auto Adjust**, and press **Enter** to automatically optimize the monitor settings.
- Press – to display the setting menu for **Contrast**. Pressing + can increase the value of the contrast; pressing – can decrease the value.
- Press + to display the setting menu for **Brightness**. Pressing + can increase the value of the brightness; pressing – can decrease the value.

3.6 Connecting the Probe



- Disconnect the probe from the system after freezing an image or powering the system off. Otherwise, the probe of the system could be damaged.
- Do not pull the probe cable forcibly. Otherwise, the probe could be damaged.

3.6.1 Connecting the Probe

1. Rotate the locking lever 90° anticlockwise to the  position, and then insert the probe connector into the probe port firmly.

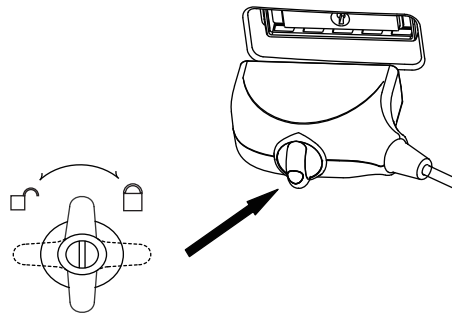

2. Rotate the locking lever 90° clockwise to lock it securely.

3.6.2 Connecting the Pencil Probe

Connect the pencil probe to the port located on the front panel of the system.

3.6.3 Disconnecting the Probe

Rotate the locking lever 90° anticlockwise to the horizontal position, and then pull the probe connector straight out vertically.

3.7 Connecting the Peripheral Device

3.7.1 Connecting the Foot Switch



- To avoid damaging the foot switch, do not place the foot switch on the system.
- Use only the foot switch provided by the manufacturer. Otherwise, the system or the foot switch may malfunction..

Connect the foot switch to the foot switch port of the system as the figure shows below.

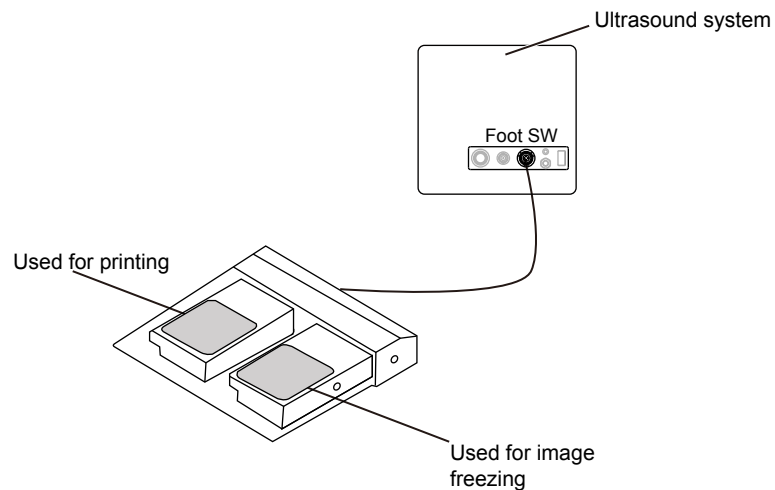

3.7.2 Connecting the Video Printer

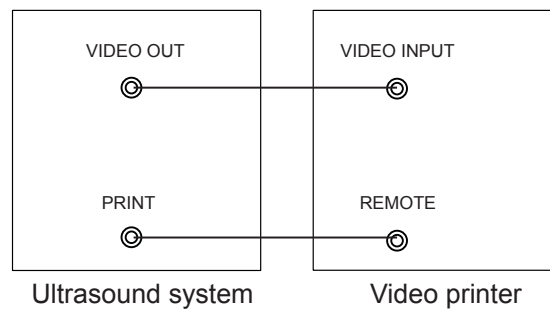

Connect the video printer to the system by BNC cable and Remote Control cable provided by the manufacturer. You can refer the installation method as the above figure shown. The video printer can work without any configurations after a successful connection.

3.7.3 Connecting the Network Printer

■ Printer Setup

1. Connect the printer to the system, and turn on the printer. The printer settings are displayed as below.

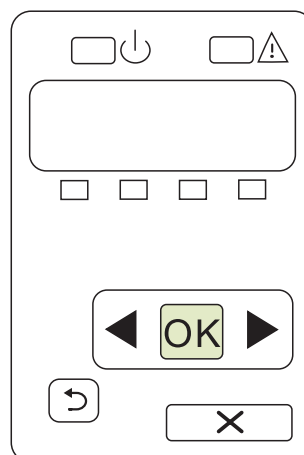

2. Press **OK** on the control panel menu of the printer.
3. Press ◀ or ▶ to select **Network Config**, and then press **OK** to confirm.

4. Press ◀ or ▶ to select **TCP IP Config**, and then press **OK** to confirm.
5. Press ◀ or ▶ to select **Manual**, and then press **OK** to confirm.
6. An IP address is displayed, change it to **192.168.254.103** by pressing ◀ or ▶, and then press **OK**.
7. If the IP address is correct, use ◀ or ▶ to select **Yes**, and then press **OK**.
If the IP address is incorrect, use ◀ or ▶ to select **No**, and then press **OK**. Repeat step 6 to enter a correct address.
8. After setting the IP address, set the subnet mask to **255.255.255.0** and the default gateway to **192.168.254.104** in the same way as described above.

■ **Ultrasound System Setup**

1. Copy the driver file **deskjet.ppd** provided by the manufacturer into the directory of the USB drive.
2. Connect the drive to the system, and then start up the system.
3. Press the **Setup** key to enter the **System Setting** menu, and click **Peripheral**.
4. Tick **Static IP** and input the settings for **IP Address**, **Netmask**, **Default Gateway** and **DICOM AE Title**.

NOTE:

IP address and **Printer IP** should be set in the same network segment.

5. Set **Default Printer** to **Net Printer**, and set the IP address of the printer.
6. Click **Add Printer** and reboot the system after the installation is complete.

3.7.4 Connecting the USB Printer

1. Connect the USB printer to the system by using the USB cable.
2. Copy the driver file **deskjet.ppd** provided by the manufacturer into the directory of the USB drive.
3. Connect the USB drive to the system, and then start up the system.
4. Press the confirm key to enter the **System Setting** menu, and click **Peripheral**.
5. Set **Default Printer** to **USB Printer**, and Click **Add Printer**.
6. Reboot the system after the installation is completed.

4 Customizing Your System

The **System Setting** menu allows you to specify general system settings, printing, measurement and calculation settings. You can also define the annotation library and shortcut keys. All your customized settings can remain even after rebooting the system.

After starting up the system, the LCD monitor displays the system desktop and the touch screen displays the application mode screen as shown in Figure 6-1. Press the **Setup** key on the control panel to enter the **System Setting** menu.

To make settings in the **System Setting** menu,

- Select one tab, and press the confirm key on the control panel to enter a setting menu.
- Move the cursor on an item by using the trackball, and press the confirm key on the control panel to select one item.
- Move the cursor to a textbox beside an item and use the key panel to manually type the value.
- Select an option from each drop-down list.
- Select **Save&Exit** to save any changes and exit the **System Setting** menu.
- Select **Exit** to quit the **System Setting** menu.

4.1 General System Settings

You can make general system settings on the **General**, **Display**, **Storage** and **KeyConfig** tabs.

4.1.1 General Settings

System Setting

General | Peripheral | Comment | Bodymark | Measure | Touch Screen | Report | DICOM | Load Default | User Security | About

General | Display | Storage | KeyConfig

Hospital Name

Freeze Response

Trackball Sensitivity

Language&Time

Language

Time Zone

Time Setting

11/01/2015 16:00:00 Date Format

Time Format

Monitor Type

Caps Lock

Clear Annot On Unfreeze

Guide Line Type

Focal Auto

Save&Exit

Exit

Figure 4-1 General Settings Menu - General Tab

Item	Description
Hospital Name	Enter the institution's name.
Freeze Response	Select the feature to be enabled after you select the Freeze key.
Trackball Sensitivity	Adjust the sensitivity for the trackball movement. A greater value brings about a higher sensitivity.
Language	Choose a system language for the user interface, and reboot the system for it to take effect.
Time Zone	Set the local time zone.
Date Format	Set the date format for the system.
Date/Time Setting	<p>Set the system date and time.</p> <p>Select this item to set the system date and time manually in the pop-up text box.</p> <p>NOTE:</p> <p>You should set the system date and time for your initial use of the system.</p>
Time Format	Set the time format between 12 Hour and 24 Hour.
Monitor Type	Set the video type.
Caps Lock	<p>Enable or disable the capital letter feature.</p> <ul style="list-style-type: none"> ● Set it to ON, all the typed letters are capital. Pressing Shift + X can enter a lower-case letter. ● Set it to OFF, all the typed letters are lowercase. Pressing Shift + X can enter a capital letter.
Clear Annot On Unfreeze	<p>Enable or disable the annotation-cleared feature after you unfreeze the image in the annotation editing mode.</p> <ul style="list-style-type: none"> ● Set it to ON, all annotations are cleared after you press the Freeze key in the annotation editing mode. ● Set it to OFF, all annotations are not cleared.
Guide Line Type	<p>Select a type for the biopsy guidelines.</p> <ul style="list-style-type: none"> ● Set it to Gun, one biopsy guideline is displayed when performing the biopsy. ● Set it to Needle, two parallel biopsy guidelines are displayed when performing the biopsy. These guidelines make up the guide zone within which is used to guide a safe biopsy.
Focal Auto	<p>Enable or disable the auto-focus feature.</p> <ul style="list-style-type: none"> ● Set it to On, the focal depth varies with the depth in the B mode. The focal depth varies with the ROI position in the CFM/PDI/TDI mode. ● Set it to Off, the system never adjusts the focal depth.

4.1.2 Display Settings

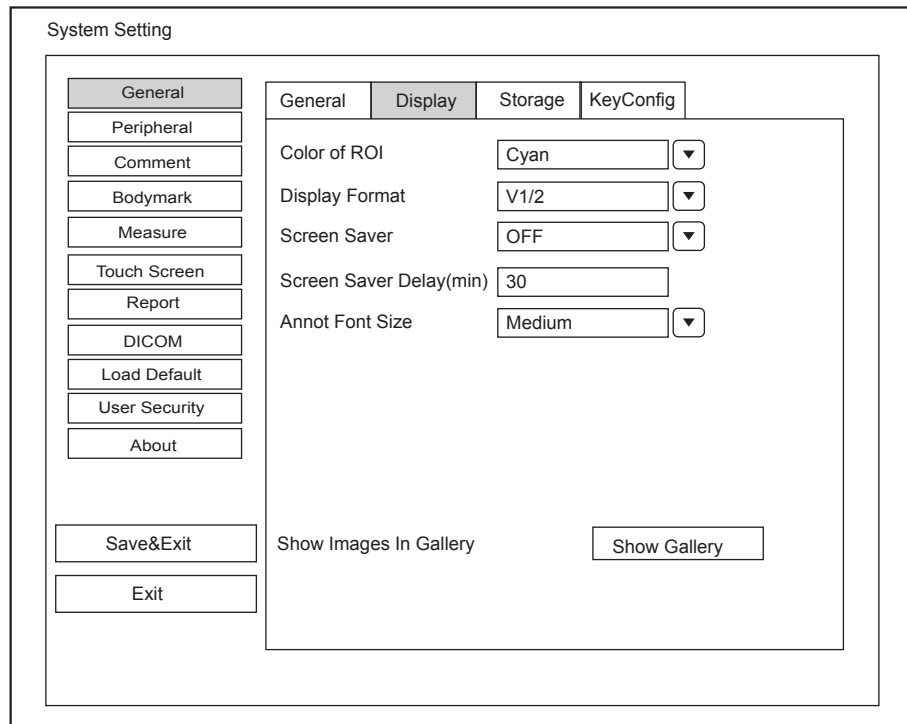

Figure 4-2 General Settings Menu - Display Tab

Item	Description
Color of ROI	Set the color for the interest region box.
Display Format	Set the default display format for the M and PW/CW modes.
Screen Saver	Enable or disable the screen saver feature.
Screen Saver Delay (min)	Set the period to activate the screen saver.
Annot Font Size	Set the font size of the annotations.
Show Images In Gallery	View images and cines coming with the system or imported from external storage devices.

■ Show Images in Gallery

Perform the following steps to perform a demonstration.

1. Click **Show Gallery** to enter the **Show Gallery** screen, as shown in Figure 4-3.

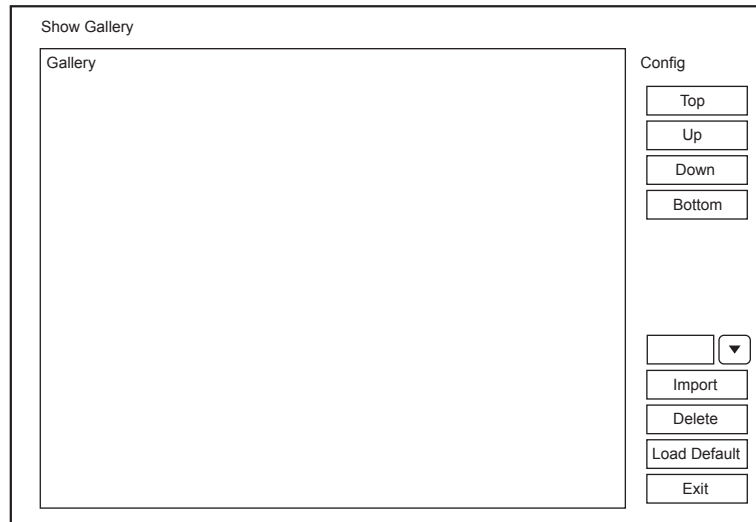

Figure 4-3 Show Gallery Screen

2. Load default demos or import demos stored in an external storage device.
 - Select a demo and click **Top**, **Up**, **Down** or **Bottom** to arrange the order.
 - Select a demo and click **Delete** to remove it from the gallery.
3. Select a demo and press the confirm key on the control panel twice to start a demonstration.
 - Press the Up/Down/Left/Right arrow key to go to the previous or next demo.
 - Press the confirm key to pause or resume the demonstration.
 - Press the **Freeze** key to stop the demonstration.

4.1.3 Storage Settings

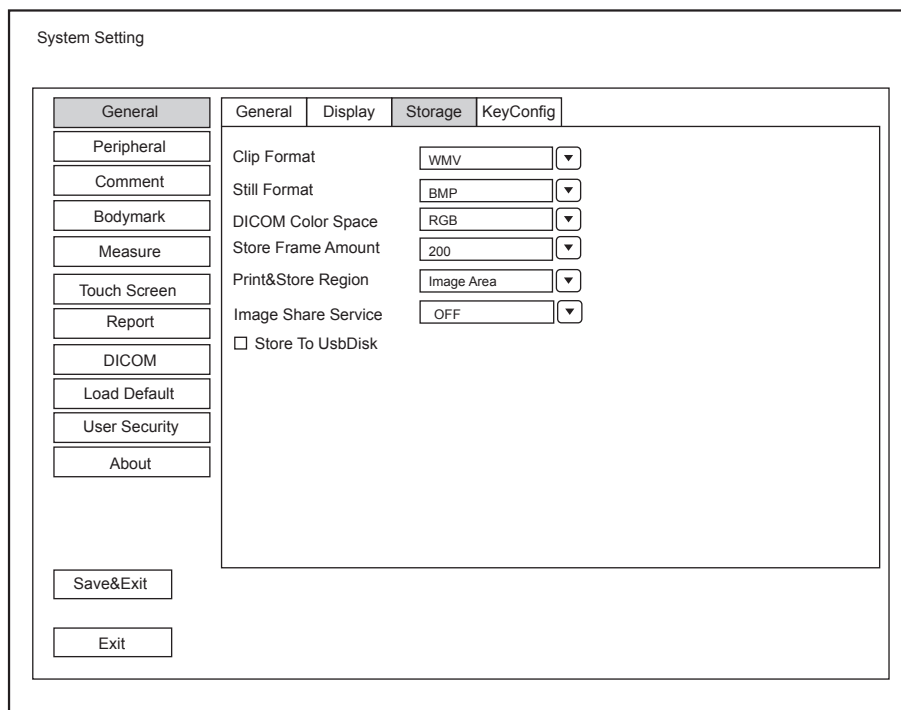

Figure 4-4 General Settings Menu - Storage Tab

Item	Description
Clip Format	Set the cine storage format.
Still Format	Set the image storage format.
DICOM Color Space	Set the type of color space of DICOM file. This feature is only available for cine stored to DICOM storage server in JPEG format.
Store Frame Amount	Set the maximum number of frames for cine.
Print&Store Region	Set the area to be printed out.
Image Share Service	Enable or disable the share feature. <ul style="list-style-type: none"> Set it to On, you can remotely access to a computer for shared files. Set it to Off, you disable the feature.
Store To UsbDisk	Tick it, after you connect the USB drive to the system, saved image are synchronously stored to the USB drive.

4.1.4 Defined-Key Settings

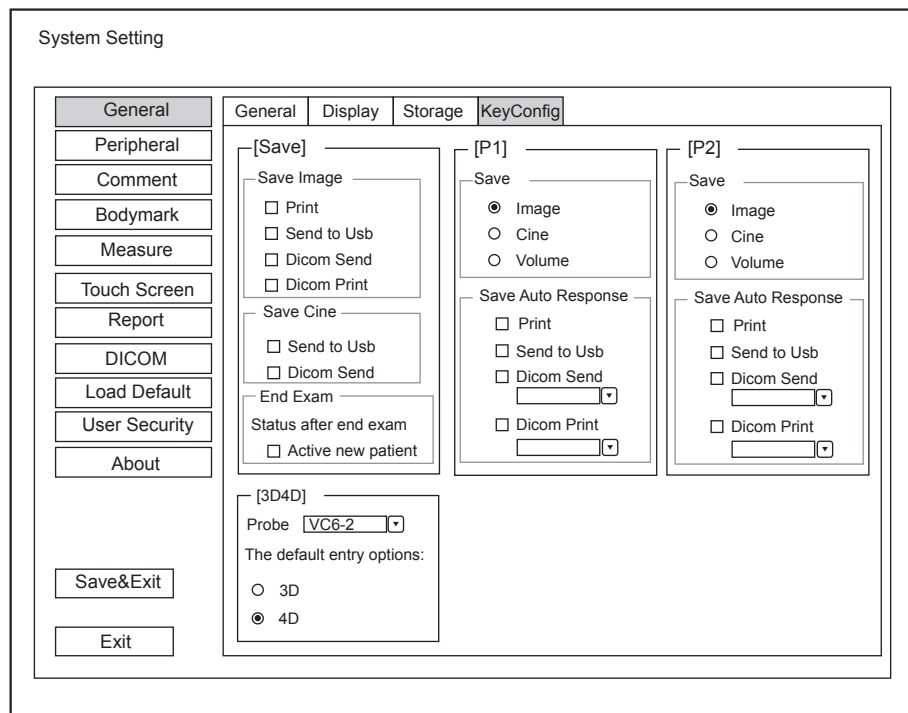

Figure 4-5 General Settings Menu - Key Configuration Tab

Item	Description
Image	Tick it and press the P1 key to save the desired image.
Cine	Tick it and press the P1 key to save the desired cine.
Volume	Tick it and press the P1 key to save the desired volume data.
Print	Tick it and press the Save or P1 key to save the desired image and print it out.
Send to USB	Tick it and press the Save or P1 key to save the desired data to the USB drive.

Item	Description
DICOM Send	Tick it and press the P1 key to send the desired data to the DICOM storage server. You can select the specific DICOM storage server from the drop-down list when defining the P1 key.
DICOM Print	Tick it and press the Save or P1 key to send the desired image to the DICOM storage server. You can select the specific DICOM print server from the drop-down list when defining the P1 key.
Activate new patient	Tick it and the New Patient screen will automatically appear after you end the exam by pressing the End Exam key.
The default entry options	Set the default inactivated mode. After pressing the 3D/4D key, the system automatically enters the inactivated 3D or 4D mode when using the volume probe selected from the drop-down list beside Probe .

4.2 Peripheral Device Settings

You can make local network settings, wireless network settings and printer settings on the Peripheral Device Settings menu. The wired network will take priority when wired network and wireless network are available at the same time.

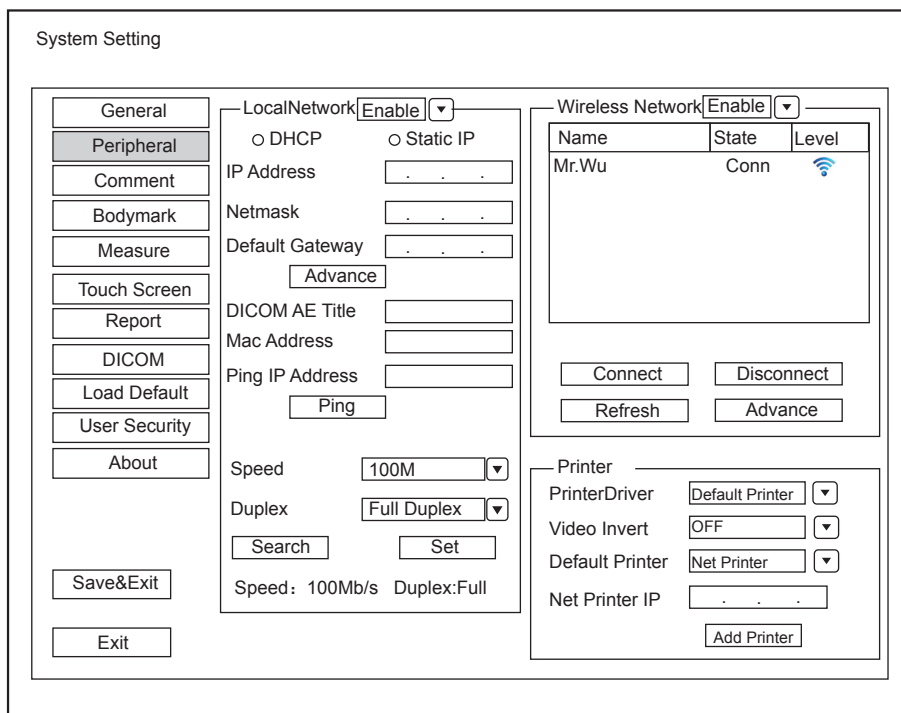

Figure 4-6 Peripheral Device Settings Menu

Local Network Settings

Item	Description
Address Mode	Select an IP address mode.
IP Address	Set the IP address of the system.

Item	Description
NetMask	Set the netmask address of the system.
Default Gateway	Set the gateway address of the system.
Speed/Duplex	Click Advance , Speed and Duplex textboxes are displayed on the menu. You can adjust the settings of these items to change the speed and communication mode of the local network. Click Set to save the settings, and then you can click Search to view your settings.
DICOM AE Title	Set the Application Entity (AE) title of the system.
Mac Address	View the MAC address of the system.
Ping IP Addr.	Type an IP address and click Ping to test the connection.

■ Wireless Settings

Item	Description
Wireless Network	Enable or disable access to wireless network.
Name	Displays the name of the wireless network.
State	Displays the connection status of the wireless network.
Level	Displays the signal strength of the wireless network.
Advance	Click Advance to view the information of your current network, and make settings of your local network.

Connect the wireless network as follows:

1. Click **Refresh** to display all wireless networks on the menu.
2. Select the desired wireless network and click **Connect**.
3. Input the password in the pop-up dialogue box if needed and click **OK**.

■ Printer Settings

Item	Description
Printer Driver	The default option is the most recently installed printer driver.
Video Invert	Color is inverted when printing the report.
Default Printer	Set the type of the default printer.
Net Printer IP	Set an IP address of the network printer.
Add Printer	Click the button and follow the on-screen instructions to install a printer driver.

4.3 Defining Annotation Library

You can add, modify, delete or arrange the predefined annotation on the Annotation Settings menu.

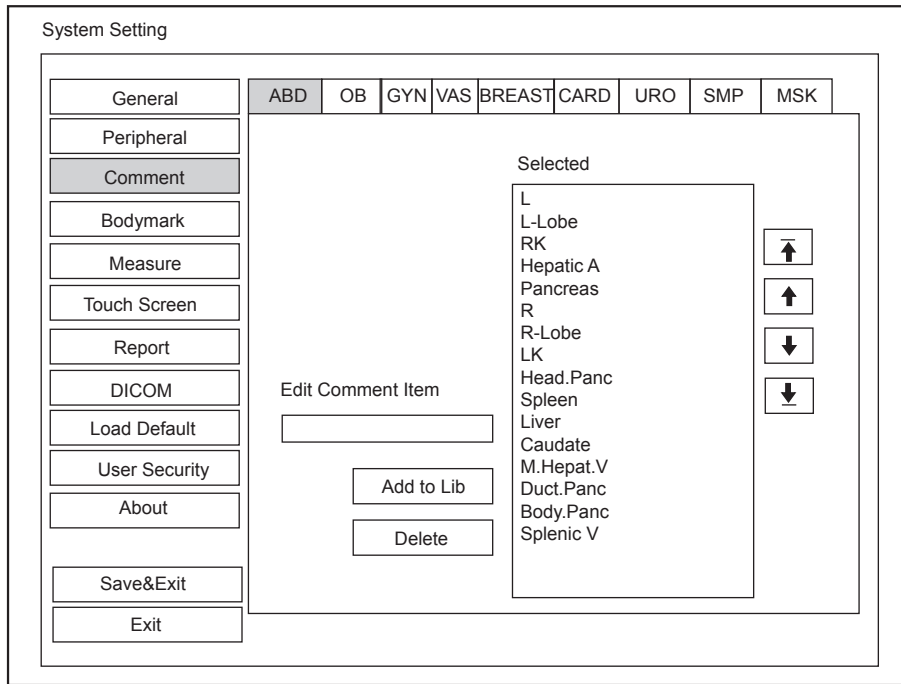





Figure 4-7 Annotation Settings Menu

- Enter an annotation in the **Edit Comment Item** textbox, and then click **Add to Lib** to create a new annotation in the library.
- Click on an annotation in the **Selected** list, and then click **Delete** to delete it from the library.
- Click on an annotation in the **Selected** list, and then click , ,  or  to arrange its display.

4.4 Body Mark Settings

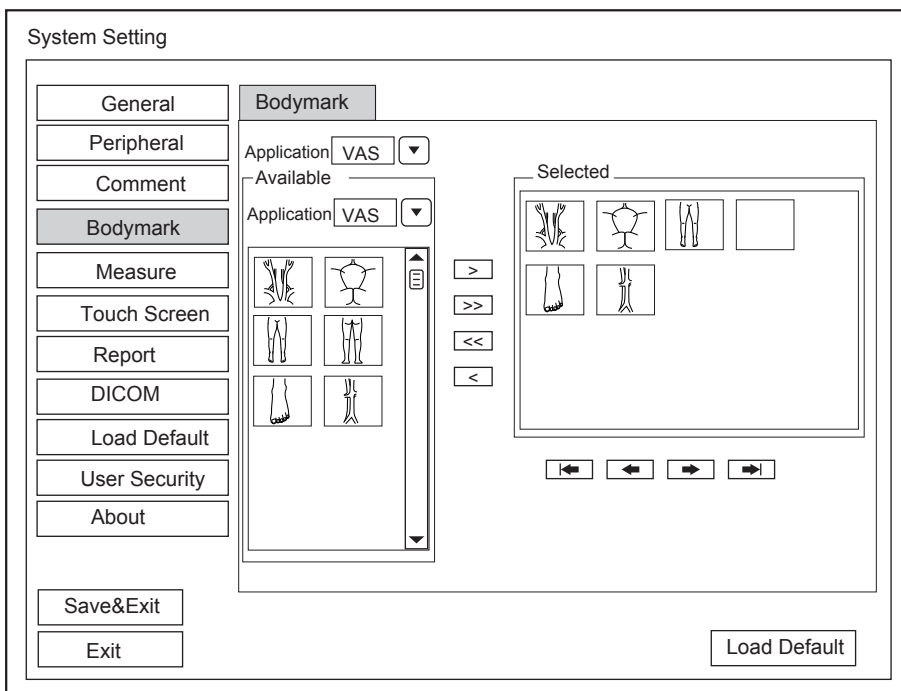





Figure 4-8 Body Mark Settings Menu

1. Select an exam type from the drop-down list beside **Application**.
2. Select a body mark library from the drop-down list beside **Application** of **Available**.

3. Add desired body marks in the selected body mark library to the **Selected** list.
 - Select a body mark and then click > to add it to the **Selected** list.
 - Click >> to add all body marks in the selected body mark library to the **Selected** list.
 - Select a body mark in the **Selected** list and click < to remove it from the **Selected** list.
 - Click << to remove all body marks from the **Selected** list.
4. Select a body mark in the **Selected** list and then click , ,  or  to arrange its display.

4.5 Measurement Settings

You can adjust measurement settings on the **General**, **Application** and **List** tabs.

4.5.1 General Measurement Settings

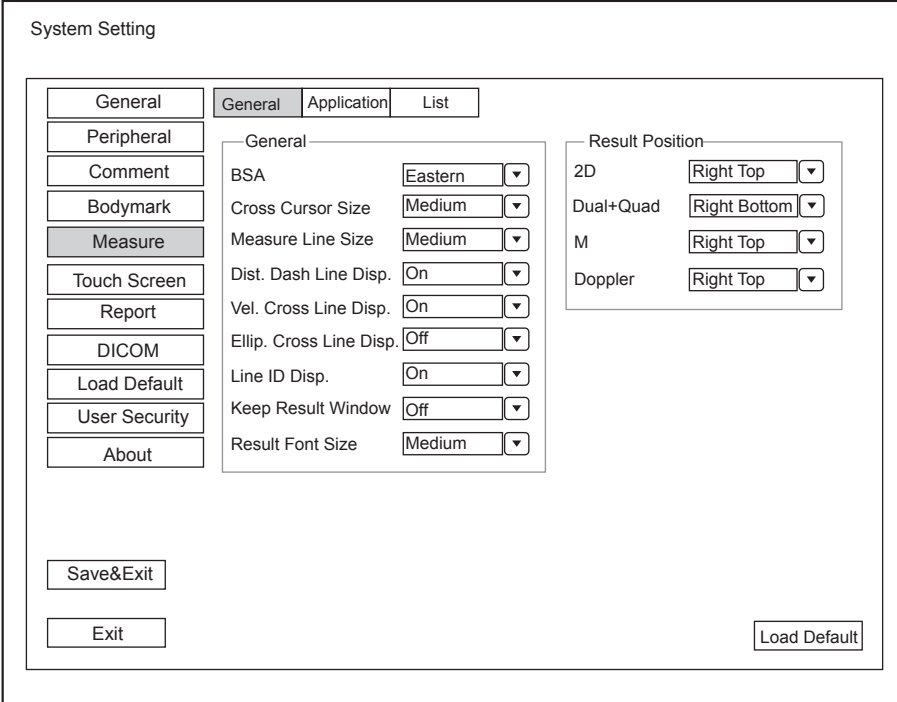

System Setting

General Application List

General

BSA Eastern

Cross Cursor Size Medium

Measure Line Size Medium

Dist. Dash Line Disp. On

Vel. Cross Line Disp. On

Ellip. Cross Line Disp. Off

Line ID Disp. On

Keep Result Window Off

Result Font Size Medium

Result Position

2D Right Top

Dual+Quad Right Bottom

M Right Top

Doppler Right Top

Save&Exit

Exit

Load Default

Figure 4-9 Measurement Settings Menu - General Tab

■ General Measurement Items

Item	Description
BSA	In accordance with the setting of this item, the system calculates BSA value automatically after you enter the height and weight of the patient on the Patient Information screen.
Cross Cursor Size	Set the size of the cross cursor.
Measure Line Size	Set the thickness of the measurement line.
Dist. Dash Line Disp.	Enable or disable the display of a dash line between two points when performing a distance measurement.
Vel. Cross Line Disp.	Enable or disable the display of a reticle between two points when performing a velocity measurement.

Item	Description
Ellip. Cross Line Disp.	Enable or disable the display of dash lines for long and short axes when performing a ellipse measurement.
Line ID Disp.	Enable or disable the display of line number when performing a measurement.
Keep Result Window	Enable or disable the display of the current result box when unfreezing the image.
Freeze on Measure	Enable or disable the frozen feature after pressing the Calc or Caliper key in the real-time mode.
Result Font Size	Set the font size of the result box.

■ **Result Position**

Item	Description
2D	Set the position of the result box.
Dual+Quad	Choose from: Right Top, Right Bottom, Left Top or Left Bottom
M	
Doppler	

4.5.2 **Application Settings**

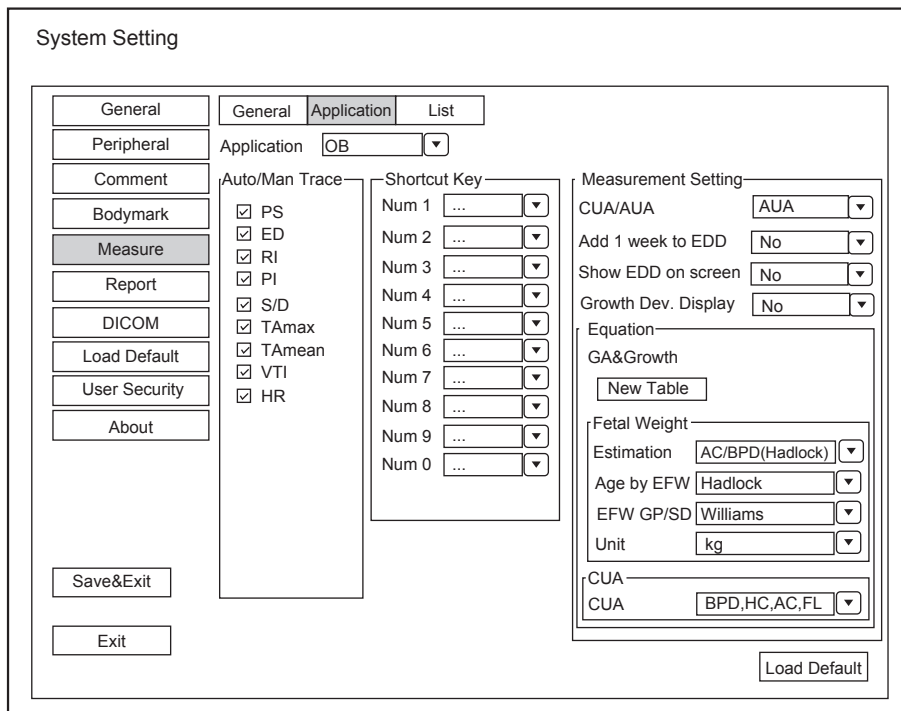

Figure 4-10 Measurement Settings Menu - Formula Tab

■ **Auto/Man Trace**

After selecting an exam type from the application drop-down list, set the measurement items of Auto/manual trace in the spectral Doppler mode.

■ **Shortcut Key**

Select **OB**, **GYN** or **Cardiac** from the drop-down list beside **Application**, and then select a measurement item from the drop-down list beside **Num 0** to **Num 9**. After making these settings, you can perform the Obstetrics, Gynecology or Cardiology measurement by using the defined shortcut key.

■ **Small Parts Measurement Settings**

Select **SMP** from the drop-down list beside **Application** and set the coefficient of the thyroid volume formula.

■ **Obstetrics Measurement Setting**

Set the formula for obstetrics measurement.

Item	Description
CUA/AUA	Set to display CUA or AUA on the measurement report. CUA stands for Composite Ultrasound Age and AUA stands for Average Ultrasound Age.
Add 1 week to EDD	Enable to add one week to EDD.
Show EDD on screen	Enable to display EDD in the measured result box.
Growth Dev. Display	Set the display format of GA deviation in the measurement report and growth graph.
Estimation	Set the formula to estimate EFW. If it is set to None , the system will not estimate fetal weight and no corresponding value displays on the measurement report.
Age by EFW	Set the formula to estimate GA by EFW. If it is set to None , the system will not estimate GA by EFW and no corresponding values are displayed on the measurement report.
EFW GP/SD	Set the formula of the fetal growth curve. If it is set to None , no values about the fetal growth curve are displayed on the measurement report.
Unit	Set the weight unit.
CUA	Set the CUA formula. If it is set to None , the system will not estimate CUA and no corresponding value displays on the measurement report.

■ **Equation Setting**

You can customize the formula for gestational age and **growth curve**.

Perform the following steps as follows:

1. Click **New Table** to bring up the **New Table** dialogue box.
2. Select **New GA Table** or **New Growth Table** and click the **OK** button. The screen shown in Figure 4-11 or Figure 4-12 pops up.

GA Table

Measurement Author Deviation

Meas -2SD Mean +2SD

Unit

	Meas[mm]	-2SD[w+d]	Mean[w+d]	+2SD[w+d]
1				
2				
3				
4				
5				
6				
7				
8				
9				
10				
11				
12				
13				
14				
15				
16				
17				
18				
19				

Figure 4-11 GA Table

Growth Table

Measurement Author Deviation

Meas -2SD Mean +2SD

Unit

	Age[w+d]	-2SD[mm]	Mean[mm]	+2SD[mm]
1				
2				
3				
4				
5				
6				
7				
8				
9				
10				
11				
12				
13				
14				
15				
16				
17				
18				
19				

Figure 4-12 Growth Table

3. Select or input the **Measurement**, **Author**, **Deviation** and the corresponding **Unit**.
4. Enter the gestational weeks and the values of measurement items in the table.
5. Click the **Save&Exit** button to save the customized formula and exit.

4.5.3 List Settings

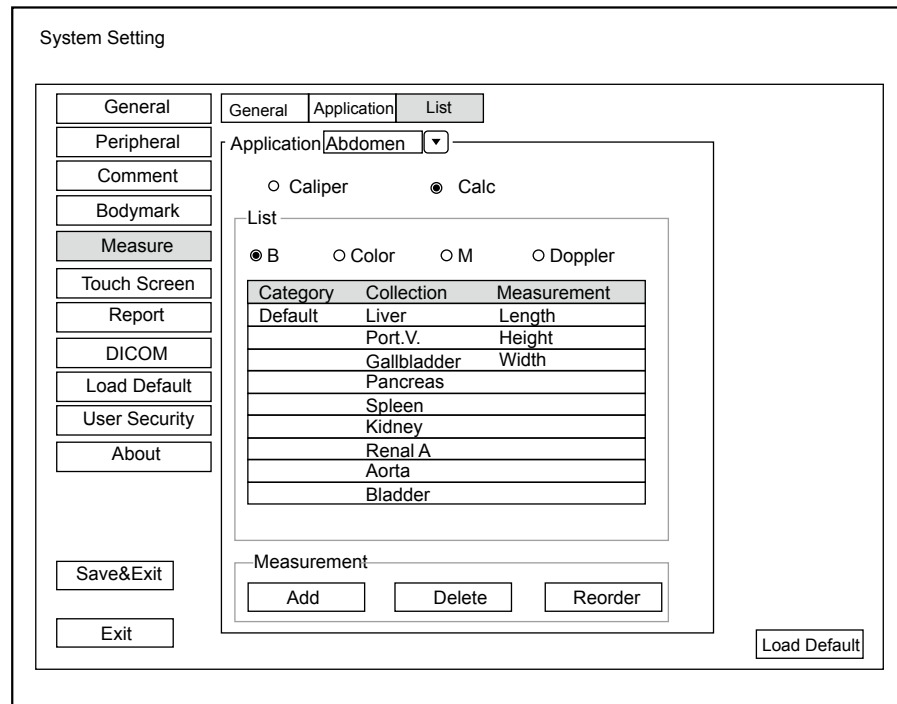

Figure 4-13 Measurement Settings Menu - List Tab

You can add, delete or reorder the measurement collections and items in each imaging mode of the selected application.

■ To Add a Collection or Measurement

Perform the following steps as follows:

1. Select an exam type from the drop-down list beside **Application**.
2. Select the **Caliper** or **Calc**.
3. Select an imaging mode in the **List** frame and click **Collection** or **Measurement**.
4. Click **Add** to add the desired collection or measurement on the pop-up screen.
5. Click **Close** to complete.

■ To Delete a Collection or Measurement

Perform the following steps as follows:

1. Select an exam type from the drop-down list beside **Application**.
2. Select the **Caliper** or **Calc**.
3. Select an imaging mode in the List frame and click the collection item or measurement item that you wish to delete.
4. Click **Delete**.

■ To Reorder the List of Collections or Measurements

Perform the following steps as follows:

1. Select an exam type from the drop-down list beside **Application**.
2. Select the **Caliper** or **Calc**.

3. Select an imaging mode in the List frame and click the **Collection** or **Measurement**.
4. Click the **Reorder** and adjust the sequence of the collection or measurement on the pop-up screen.

4.6 Touch-Screen Settings

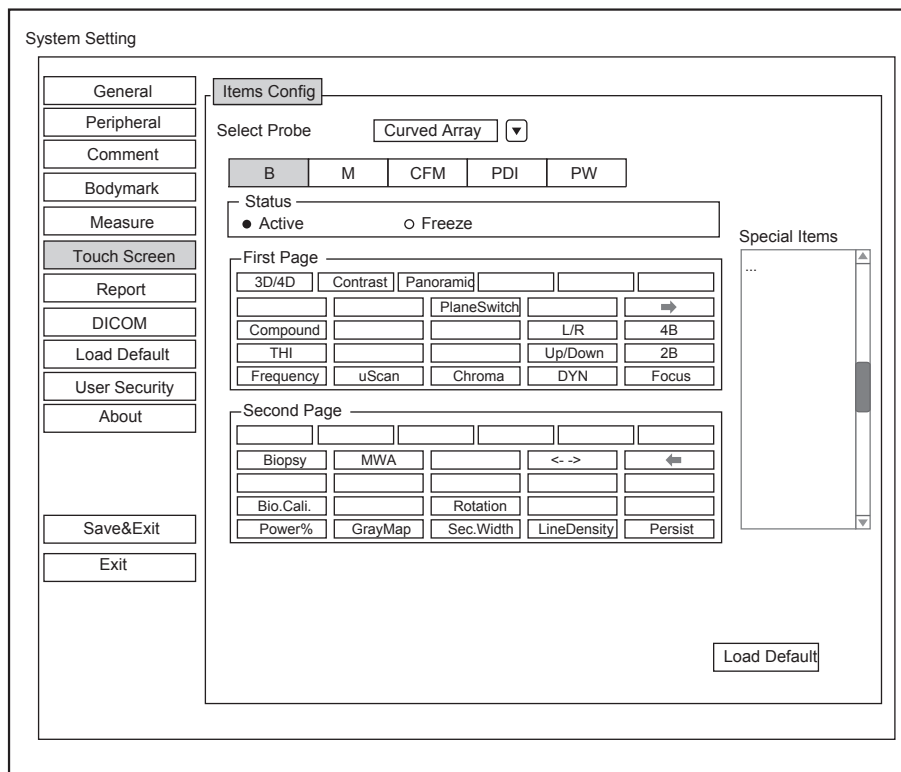

Figure 4-14 Measurement Settings Menu - Touch Screen Tab

You can add, modify, delete the parameter displayed on the first or second page of the touch screen after selecting probe type, exam type or imaging mode.

4.6.1 Adding A Parameter

Click a blank box, and then click the desired parameter in the **Special Items** list to add it.

4.6.2 Modifying A Parameter

Click a parameter, and then click the desired parameter in the **Special Items** list to replace it.

4.6.3 Deleting A Parameter

Click a parameter, and then click ... in the **Special Items** list to delete the desired parameter.

4.7 Report Settings

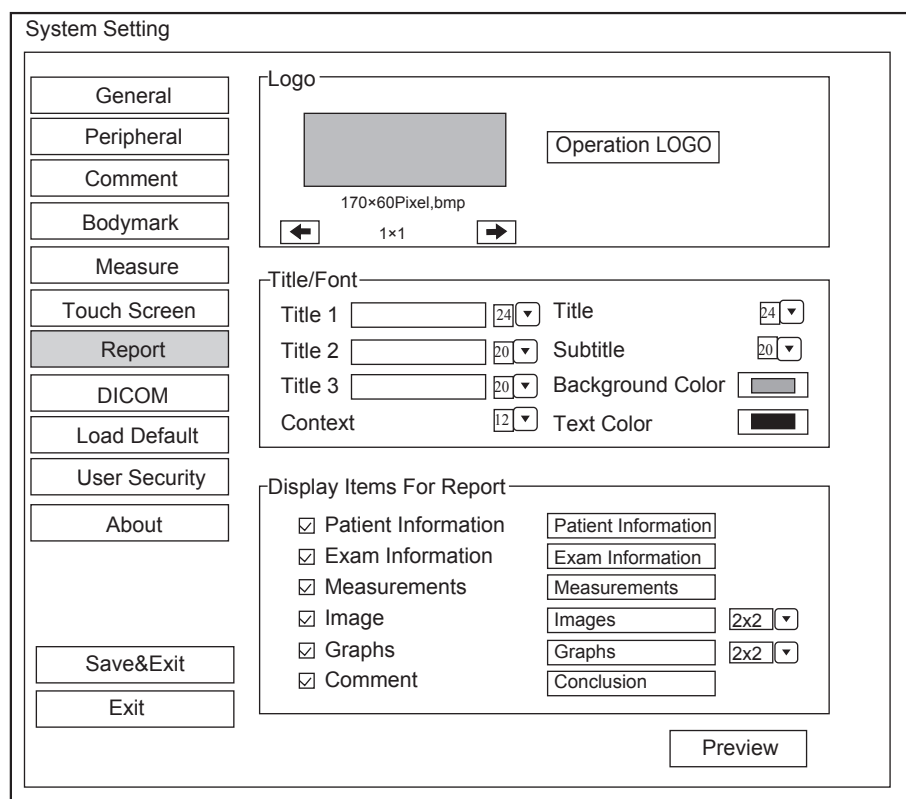



Figure 4-15 Report Settings Menu

Item	Description
Logo	<p>Connect the USB drive containing the report logo (170×60 pixels, bmp format) to the system. Operation LOGO is highlighted after the USB drive is successfully detected by the system.</p> <p>Click Operation LOGO, and then click the desired logo in the pop-up dialogue box to add the logo.</p> <p>If there is more than one logo, you can click  or  to select the desired logo.</p>
Title1/2/3	Input the title name in the textbox and then set the font size using the drop-down list.
Title	Set the font size of the headline.
Subtitle	Set the font size of the subtitle.
Context	Set the text font size.
Background Color	Set the background color of the measurement report.
Text Color	Set the text color.
Display Items for Report	Select items to be displayed on the measurement report. Patient and exam information is displayed on the report by default. Other information can also be displayed on the report after you tick Measurements , Image , Graphs or Comments .

After settings, you can click **Preview** to preview the report. Press the **Freeze** button on the control panel to exit.

4.8 Configuring DICOM

4.8.1 Storage Service Settings

You can connect the system to the DICOM storage server and adjust the relevant settings on the Storage Service tab.

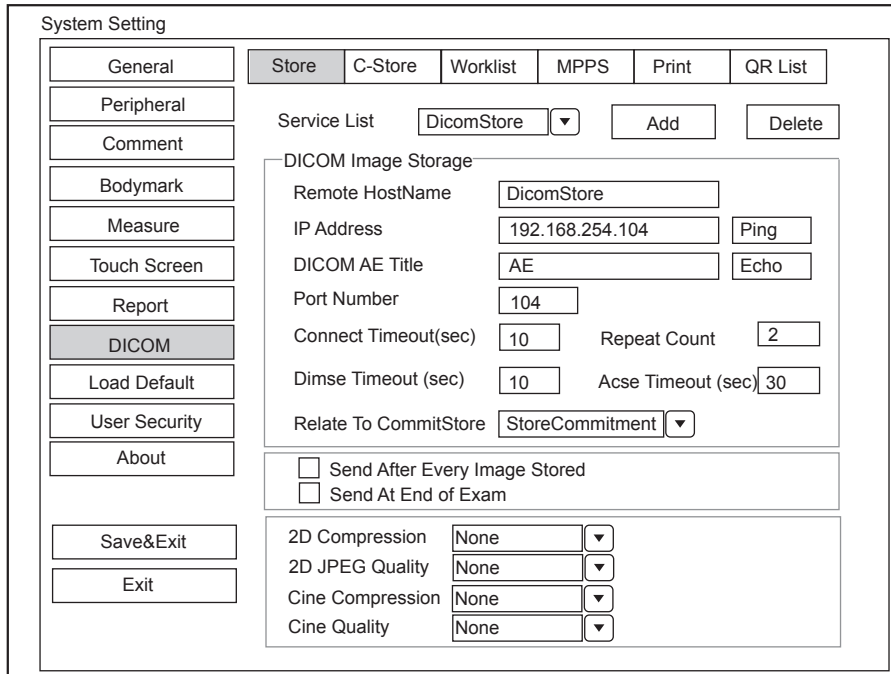

Figure 4-16 DICOM Settings Menu - Storage Service Tab

Item	Description
Service List	Select the DICOM storage server. <ul style="list-style-type: none"> • Select Append from the drop-down list beside Service List, input the relevant parameters information and click Add to add a new server. • Select any server from the drop-down list and click Delete to delete the server.
Remote Host Name	Enter the name of the DICOM storage server.
IP Address	Set the IP address of the DICOM storage server. After the setting, click Ping to test the connection.
DICOM AE Title	Set the Application Entity (AE) title of the DICOM storage server.
Port Number	Set the port number of the DICOM storage server.
Connect Timeout(sec)	Set the time limit of network connection timeout.
Repeat Count	Set the number of repeated attempts for connecting to the DICOM storage server.
Dimse Timeout(sec)	Set the timeout time for sending the Dimse command.
Acse Timeout(sec)	Set the timeout time for sending the Acse command.
Relate to CommitStore	Select the desired DICOM commitment storage server to be associated with the DICOM storage server.

Item	Description
Send After Every Image Stored	Tick this item and the system sends an image to the DICOM storage server every time the image is saved.
Send At End of Exam	Tick this item and the system sends all saved images to the DICOM storage server after the exam is completed.
2D Compression	Select the compression format of image stored to DICOM storage server.
2D JPEG Quality	Select the quality of image in JPEG format stored to DICOM storage server.
Cine Compression	Select the compression format of cine stored to DICOM storage server.
Cine JPEG Quality	Select the quality of cine in JPEG format stored to DICOM storage server.

Click **Echo** to verify the connection between the system and the server after you input the settings. A summary displays if the connection is verified.

4.8.2 Commitment Settings

You can connect the system to the DICOM commitment storage server and adjust the relevant settings on the Commitment Storage tab.

The screenshot shows the 'System Setting' window with the 'DICOM' tab selected. Under the 'DICOM' tab, the 'Commitment Storage' settings are visible. The 'Service List' is set to 'StoreCommitment'. The 'Remote HostName' is 'StoreCommitment', 'IP Address' is '192.168.254.104', 'DICOM AE Title' is 'AE', and 'Port Number' is '105'. The 'Connect Timeout(sec)' is '10', 'Repeat Count' is '2', 'Dimse Timeout(sec)' is '10', and 'Acse Timeout(sec)' is '30'. There is a checkbox for 'Synchronously Receive N-EVENT-REPORT Message' which is currently unchecked.

Figure 4-17 DICOM Settings Menu - Commitment Storage Tab

Item	Description
Service List	Select the DICOM commitment storage server. <ul style="list-style-type: none"> Select Append from the drop-down list beside Service List, input the relevant parameters information and click Add to add a new server. Select any server from the drop-down list and click Delete to delete the server.
Remote Host Name	Set the name of the DICOM commitment storage server.

Item	Description
IP Address	Enter the IP address of the DICOM commitment storage server. After the setting, click Ping to test the connection.
DICOM AE Title	Set the Application Entity (AE) title of the DICOM commitment storage server.
Port Number	Set the port number of the DICOM commitment storage server.
Connect Timeout(sec)	Set the time limit for the network connection timeout.
Repeat Count	Set the number of repeated attempts for connecting to the DICOM commitment storage server.
Dimse Timeout(sec)	Set the timeout time for sending the Dimse command.
Acse Timeout(sec)	Set the timeout time for sending the Acse command.
Synchronously Receive N-EVENT-REPORT Message	Tick this item and the system receives the N-EVENT-REPORT messages synchronously with the storage server.

Click **Echo** to verify the connection between the system and the server after you input the settings. A summary displays if the connection is verified.

4.8.3 DICOM Worklist Settings

You can connect the system to the DICOM worklist server and adjust the relevant settings on the Worklist tab.

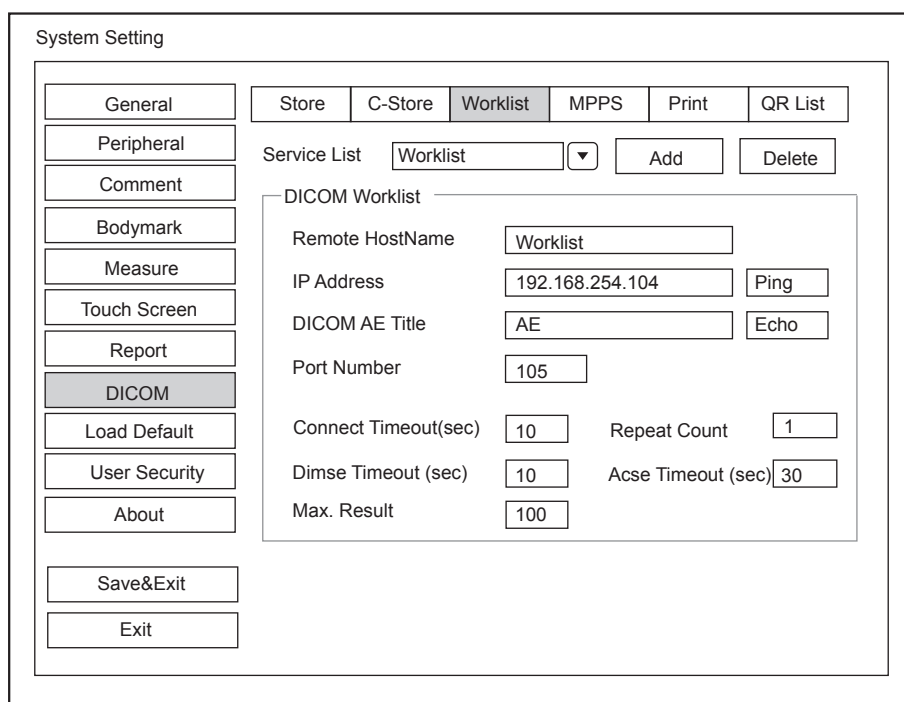

Figure 4-18 DICOM Settings Menu - Worklist Tab

Item	Description
Service List	Select the DICOM worklist server. <ul style="list-style-type: none"> Select Append from the drop-down list beside Service List, input the relevant parameters information and click Add to add a new server. Select any server from the drop-down list and click Delete to delete the server.
Remote Host Name	Enter the name of the DICOM worklist server.
IP Address	Set the IP address of the DICOM worklist server. After the setting, click Ping to test the connection.
DICOM AE Title	Set the Application Entity (AE) title of the DICOM worklist server.
Port Number	Set the port number of the DICOM worklist server.
Connect Timeout(sec)	Set the time limit for the network connection timeout.
Repeat Count	Set the number of repeated attempts for connecting to the DICOM worklist server.
Dimse Timeout(sec)	Set the timeout time for sending the Dimse command.
Acse Timeout(sec)	Set the timeout time for sending the Acse command.
Max. Result	Set the maximum number of patient records that can be sent to the system.

Click **Echo** to verify the connection between the system and the server after you input the settings. A summary displays if the connection is verified.

4.8.4 MPPS (Modality Performed Procedure Step) Settings

You can connect the system to the MPPS server and adjust the relevant settings on the MPPS tab.

The screenshot shows the 'System Setting' window with the 'MPPS' tab selected. The sidebar on the left contains buttons for General, Peripheral, Comment, Bodymark, Measure, Touch Screen, Report, DICOM (highlighted), Load Default, User Security, About, Save&Exit, and Exit. The main content area has tabs for Store, C-Store, Worklist, MPPS, Print, and QR List. Under the MPPS tab, there is a 'Service List' dropdown set to 'MPPS' with 'Add' and 'Delete' buttons. Below this is the 'DICOM MPPS' section with the following fields: Remote HostName (MPPS), IP Address (192.168.254.104) with a 'Ping' button, DICOM AE Title (AE) with an 'Echo' button, Port Number (109), Connect Timeout(sec) (10), Repeat Count (2), Dimse Timeout (sec) (10), and Acse Timeout (sec) (30).

Figure 4-19 DICOM Settings Menu - MPPS Tab

Item	Description
Service List	Select the MPPS server. <ul style="list-style-type: none">• Select Append from the drop-down list beside Service List, input the relevant parameters information and click Add to add a new server.• Select any server from the drop-down list and click Delete to delete the server.
Remote Host Name	Enter the name of the MPPS server.
IP Address	Set the IP address of the MPPS server. After the setting, click Ping to test the connection.
DICOM AE Title	Set the Application Entity (AE) title of the MPPS server.
Port Number	Set the port number of the MPPS server.
Connect Timeout(sec)	Set the time limit for the network connection timeout.
Repeat Count	Set the number of repeated attempts for connecting to the MPPS server.
Dimse Timeout(sec)	Set the timeout time for sending the Dimse command.
Acse Timeout(sec)	Set the timeout time for sending the Acse command.

Click **Echo** to verify the connection between the system and the server after you input the settings. A summary displays if the connection is verified.

4.8.5 Print Service Settings

You can connect the system to the print service server and adjust the relevant settings on the Print Service tab.

System Setting

General Store C-Store Worklist MPPS **Print** QR List

Peripheral

Comment

Bodymark

Measure

Touch Screen

Report

DICOM

Load Default

User Security

About

Service List DicomPrint Add Delete

DicomPrint

Remote HostName DicomPrint

IP Address 192.168.254.104 Ping

DICOM AE Title AE Echo

Port Number 109 Connect Timeout(sec) 10

Properties

Format 1×1 Trim YES

Priority MED Border WHITE

Medium PAPER Empty Image WHITE

Orientation PORTPAIT Color Gray

Film Size A4 Min Density 20

Film Destination MAGAZINE Max Density 320

Magnification CUBIC Configure Information

Copies 1 Film Session Label

Smoothing Type 1

Save&Exit

Exit

Figure 4-20 DICOM Settings Menu - Print Service Tab

Item	Description
Service List	<p>Select the DICOM print server.</p> <ul style="list-style-type: none"> Select Append from the drop-down list beside Service List, input the relevant parameters information and click Add to add a new server. Select any server from the drop-down list and click Delete to delete the server.
Remote Host Name	Enter the name of the DICOM print server.
IP Address	<p>Set the IP address of the DICOM print server.</p> <p>After the setting, click Ping to test the connection.</p>
DICOM AE Title	Set the Application Entity (AE) title of the DICOM print server.
Port Number	Set the port number of the DICOM print server.
Format	Set the print format.
Trim	Set to print or not to print a crop box around each image.
Priority	Set the print job priority.
Border	Set the color of the border to fill in the gap between the images.
Medium	Select the print medium.
Empty Image	Set the color of the empty images.

Item	Description
Orientation	Set the print orientation.
Color	Set the color of the image.
Film Size	Set the film size.
Min Density	Set the minimum density level of the film.
Film Destination	Set the film destination. Choose from: MAGAZINE or PROCESSOR <ul style="list-style-type: none"> ● Set it to MAGAZINE, the image will be stored in a film magazine. ● Set it to PROCESSOR, the image will be processed in a film processor.
Max Density	Set the maximum density level of the film.
Magnification	Set the method used for magnifying images during the print.
Configure Information	Make special image quality settings.
Copies	Set the number of copies to print.
Film Session Label	Enter a name to be applied on a group of the film labels.
Smoothing Type	Set the value of magnification interpolation for the printer.

Click **Echo** to verify the connection between the system and the server after you input the settings. A summary displays if the connection is verified.

4.8.6 QR List

You can connect the system to the QR service server and adjust the relevant settings on the **QR List** tab.

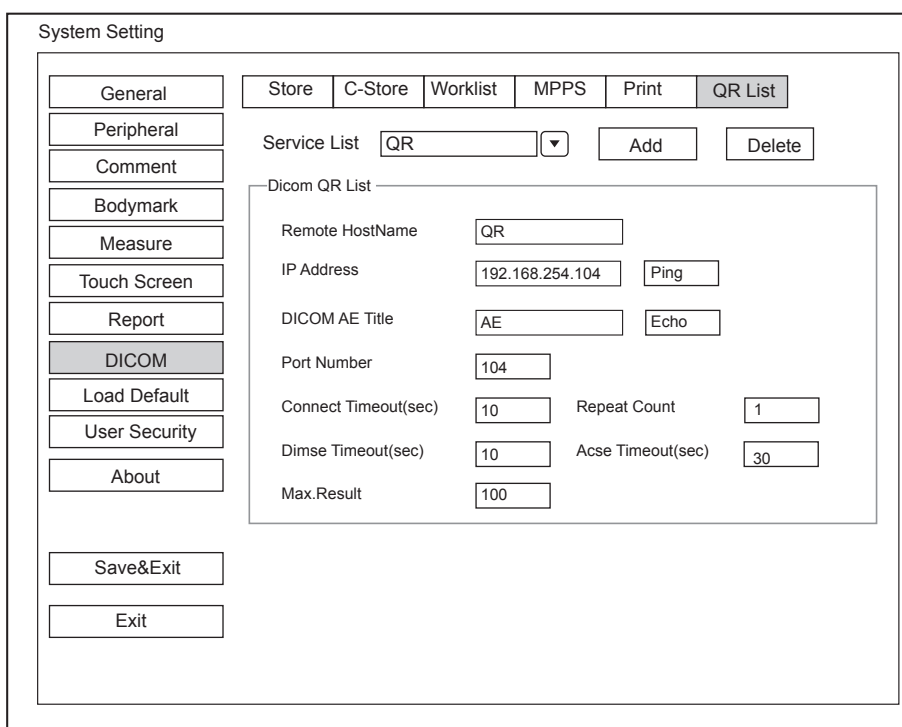

Figure 4-21 DICOM Settings Menu - QR List Tab

Item	Description
Service List	Select the QR server. <ul style="list-style-type: none"> • Select Append from the drop-down list beside Service List, input the relevant parameters information and click Add to add a new server. • Select any server from the drop-down list and click Delete to delete the server.
Remote Host Name	Enter the name of the QR server.
IP Address	Set the IP address of the QR server. After the setting, click Ping to test the connection.
DICOM AE Title	Set the Application Entity (AE) title of the QR server.
Port Number	Set the port number of the QR server.
Connect Timeout(sec)	Set the time limit for the network connection timeout.
Repeat Count	Set the number of repeated attempts for connecting to the QR server.
Dimse Timeout(sec)	Set the timeout time for sending the Dimse command.
Acse Timeout(sec)	Set the timeout time for sending the Acse command.
Max. Result	Set the maximum number of patient records that can be sent to the system.

Click **Echo** to verify the connection between the system and the server after you input the settings. A summary displays if the connection is verified.

4.9 Defining System Defaults

You can define your system defaults on the Loading Defaults Menu.

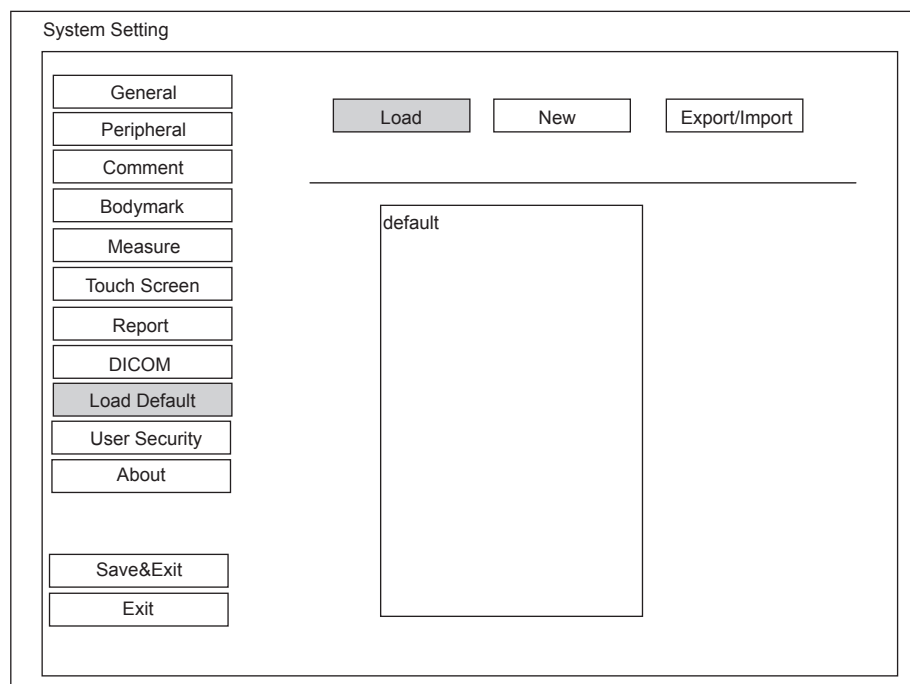

Figure 4-22 Loading Defaults Menu

■ **To Load System Defaults**

1. Click **Load**, select a setting name, and then a dialogue box appears.
2. Type **Y** on the control panel to confirm and begin loading;
Or, type **N** on the control panel to cancel loading;
Press the **Delete** key on the control panel to delete the system defaults.
3. Select **OK** to confirm it.

■ **To Create System Defaults**

Click **New**, enter a setting name in the text box. The created setting name will be listed on the Loading Defaults Menu.

■ **To Export or Import System Defaults**

Click **Export/Import** to enter the following menu.

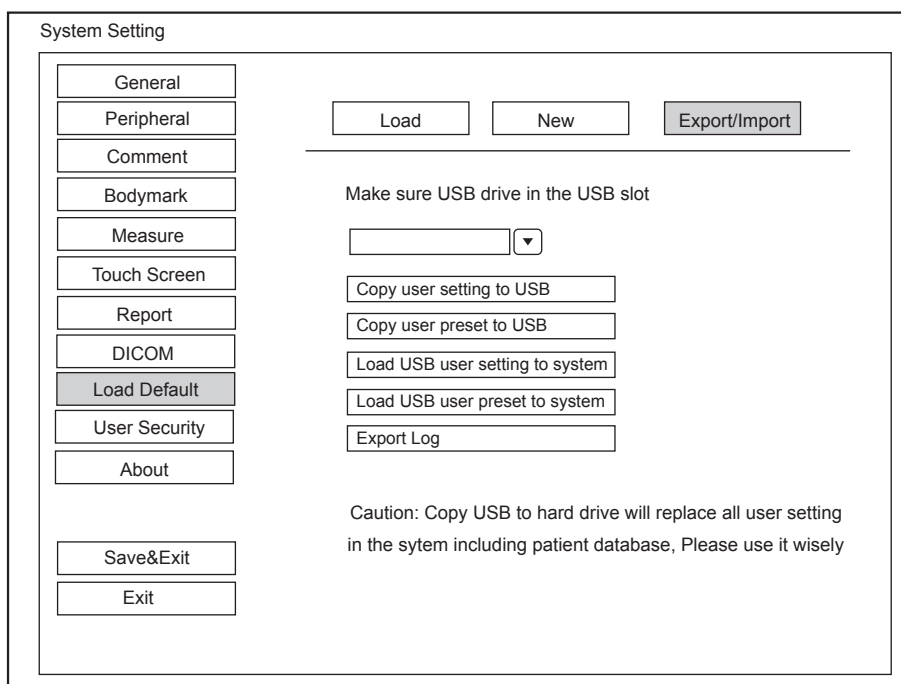



Ensure the USB drive is connected to the system before exporting or importing the system defaults.

- Click **Copy user setting to USB** to back up the system defaults to the USB drive.
- Click **Copy user preset to USB** to back up the customized system defaults to the USB drive.
- Click **Load USB user setting to system** to copy the system settings to the system.
- Click **Load USB user preset to system** to copy the customized system to the system.
- Click **Export Log** to export the log to the USB drive.

4.10 User Security

The user security settings can be used to protect patient data and the feature is disabled by default. If the feature is enabled, user can log in the system by the following two ways.

- Account Login

Account login contains administrator account login and ordinary user account login. User can log in the system by inputting user name and password. When you enter the system, the  icon pops up on the main screen. Click the  icon to lock the current user or switch to other users.

- Emergency Login

User can log in the system through emergency mode without inputting user name or password. But user can not access previous patient data in the system.

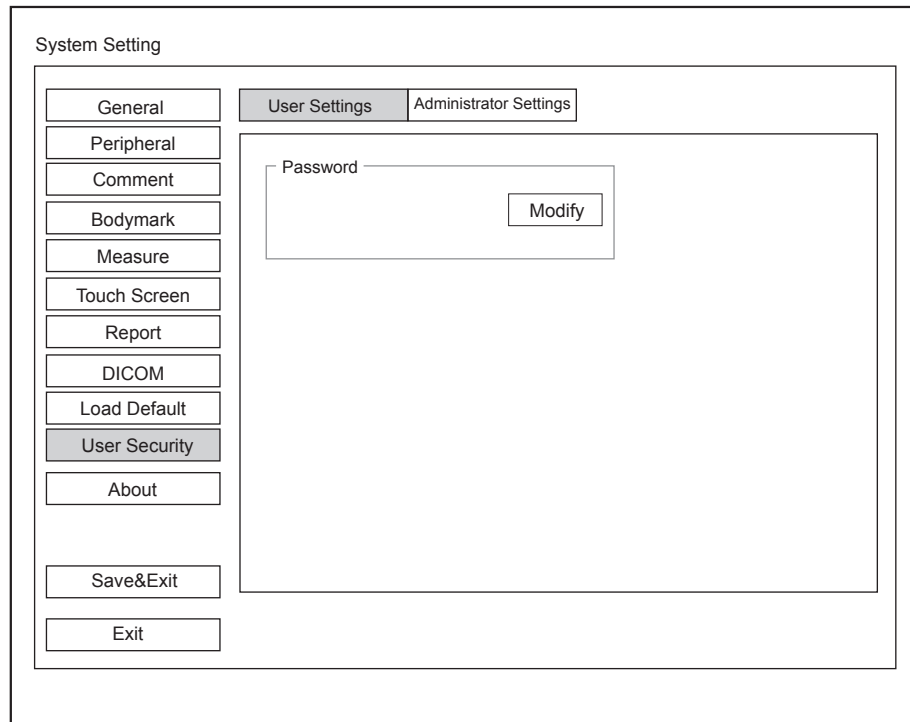

Figure 4-23 User Safety Settings Menu - User Settings Tab

Ordinary user can modify password on **User Settings** tab.

4.10.1 Administrator Settings

When user first logs in the administrator settings screen, user name and password should be entered to make user security settings.

NOTE:

- It's recommended to modify the password after the administrator logs in the system for the first time.
- User name is case-sensitive.

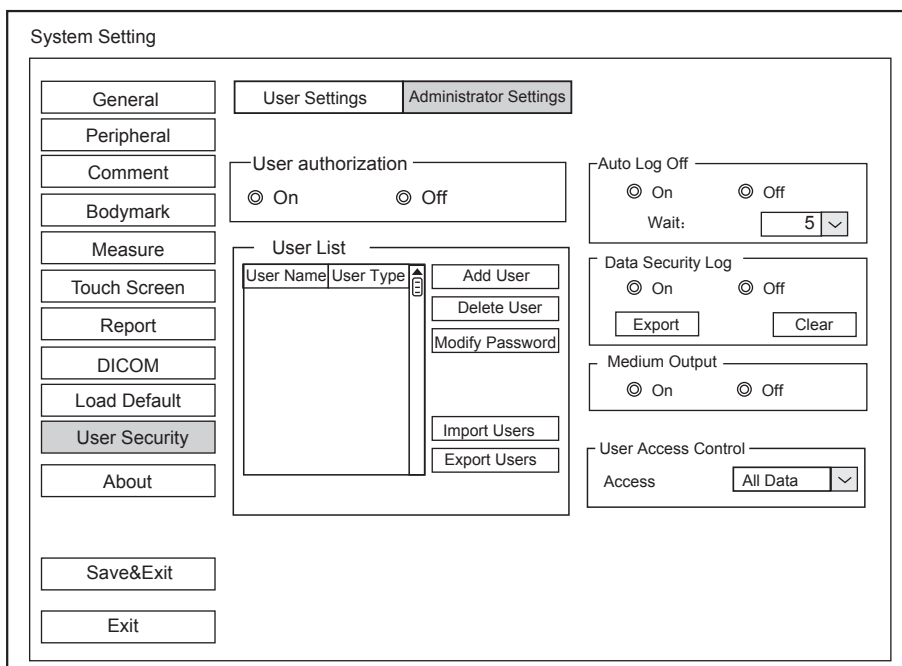

Figure 4-24 User Safety Settings Menu - Administrator Settings Tab

Item	Description
User authorization	<p>User can enable or disable the user authorization function on Administrator Settings tab.</p> <p>When user authorization function is enabled, user should input the user name and password on login screen.</p>
Account management list	<p>Add user: Click Add User, input the user name and set the password in the pop-up dialog box.</p>
	<p>NOTE:</p> <ul style="list-style-type: none"> • Only ordinary user account can be added. • Password must contain 8 -16 characters, at least including two combinations of number, letter or special character. Letters are case-sensitive.
	<p>Delete user: Click Delete User and delete the selected user according to the system prompt.</p>
	<p>Modify password: Click Modify Password and modify the selected password according to the system prompt.</p>
	<p>Import users: Click Import Users> Import to Medium on the pop-up dialog box, and click Import.</p> <p>NOTE:</p> <p>Only account data exported from the system in the same series models produced by the manufacturer can be imported.</p>
<p>Export users: Click Export Users > Export to Medium on the pop-up dialog box, and click Export.</p>	

Item	Description
Auto lock off	<p>User can enable or disable the auto logout function.</p> <p>Set the wait time before the system log out automatically when the system is idle.</p> <p>If the system is idle for a set period of wait time, the system will automatically lock the current user and return to the login screen.</p>
Data security log	<p>Data security log is used to record the operation performed by user, including login, logout, patient data viewing, modification, export, and operation time, date and user name, but no patient information will be recorded.</p> <p>Only administrator can export data security log to an external storage device or delete the data security log.</p>
Medium export	<p>When user authorization function is enabled, administrator can enable or disable the medium output feature.</p> <p>NOTE:</p> <p>When the user authorization function is disabled, the medium output is enabled by default.</p>
User access control	<p>User access control is used to set the access authorization for patient data.</p> <ul style="list-style-type: none"> ● If All Data is selected, both administrator and ordinary user can access all patient data. ● If Private Data is selected, administrator can access all patient data and ordinary user can only access the patient data collected by the user itself.

4.11 Viewing System Information

Press the **Setup** key on the control panel and select **About** on the pop-up menu to enter the system information menu.

4.11.1 General Information

You can view the current hardware version, the software version and the control number on the **General** tab. The control number is a unique number for the system.

4.11.2 Acoustic Output

You can view the acoustic output data of probes in different modes on the **Acoustic Output** tab.

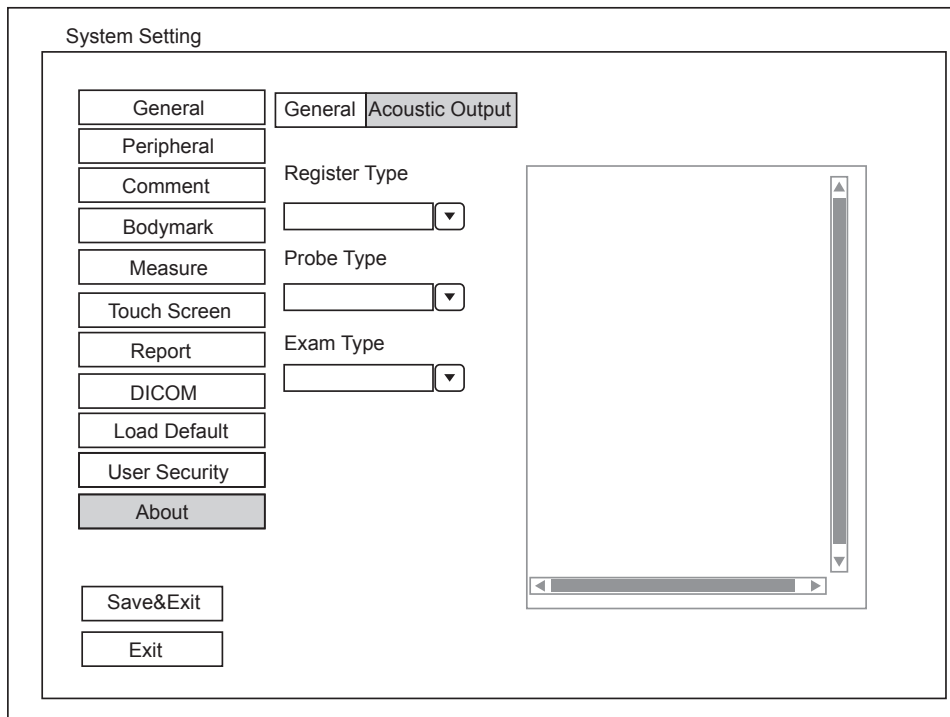



Figure 4-25 About Menu - Acoustic Output Tab

4.11.3 Touch Screen Information

Hold  on the control panel to enter the following screen.

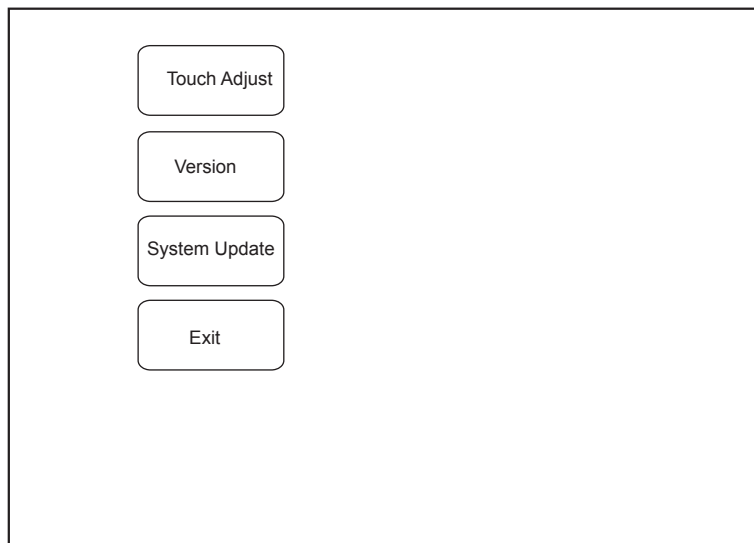



Figure 4-26 Touch-Screen Information Screen

- Press the Freeze key on the control panel or tap **Touch Adjust** to calibrate the touch screen. For details, refer to Section 4.12 Calibrating the Touch Screen.
- Tap **Version** to view the version information about the touch screen.
- If the USB drive written with the software of the touch screen, the USB icon is highlighted, and you can click **System Update** to update the software.

4.12 Calibrating the Touch Screen

Perform the following steps to calibrate the touch screen

1. Hold  on the control panel.
2. Tap **Touch Adjust** to enter the Touch Adjust screen.
3. Tap the center of every pop-up  continuously to calibrate the touch screen.

Press the **Freeze** key on the control panel to exit at any time.

This page is intentionally left blank.

5 Preparing for an Exam

You can start an exam without entering any patient information. To avoid patient identification errors, you should always verify the identification information with the patient.

5.1 Acquiring Patient Information

You can acquire the patient information in the following instructions:

- Create new patient information
- Retrieve archived patient information
- Receive patient information using the DICOM worklist

5.1.1 Beginning a New Patient

Press the **Patient** key on the control panel to display the **Patient Information** screen.

The screenshot shows a software window titled "New Patient". It is divided into two main sections: "Base Information" and "Exam Information".

Base Information:

- Patient ID: [text box] [Auto button]
- Last Name: [text box] M.I. [text box]
- First Name: [text box]
- DOB: [MM/DD/YYYY] Age: [] Y [] M [] D
- Sex: [Unknown] [dropdown arrow]
- Accession#: [text box]
- Weight: [] kg [] lb
- Height: [] cm [] in
- BSA(m²): [] [dropdown arrow]
- BP(mmHg): [] / [] (KPa) [] / []
- Comments: [text box]

Exam Information:

A row of tabs is visible: ABD (selected), OB, GYN, Cardiac, Vascular, Urology, SMP, PED, MSK, Nerve, Ortho, Other.

Fields below the tabs:

- Description: [text box]
- Chief Complaint: [text box]
- Past History: [text box]
- Referring.M.D: [text box] [dropdown arrow]
- Performing.M.D: [text box] [dropdown arrow]
- Sonographer: [text box] [dropdown arrow]
- Comments: [text box]

At the bottom right, there are four buttons: Patient List, WorkList, OK, and Cancel.

Figure 5-1 New Patient Screen

NOTE:

You can move the cursor by using the trackball, and then press the confirm key on the control panel to select the desired item.

Perform the following steps to begin a new patient.

1. Enter relevant patient information

Patient ID	Enter the patient ID, special characters are prohibited to be entered. The system will generate the patient ID automatically according to the current system time if this item is left blank. NOTE: The patient ID is an important identification, once it is saved, you cannot modify it.
Name	Enter the First Name , M.I (middle name) or Last Name of the patient.
DOB	Enter manually the date of birth for the current patient. You can set Date Format on the General Settings menu.
Age	The patient's age will be automatically calculated if you enter the information in the DOB textbox.
Sex	Enter manually the gender for the current patient.
Accession#	Enter manually the exam ID for the current patient, special characters are prohibited to be entered.
Weight and Height	Enter manually the weight and height for the current patient.
BSA	The system will automatically calculate the body surface area after you enter the weight and height. You can select the calculation formula from the corresponding drop-down list
BP	Enter manually the blood pressure for the current patient.
Comments	Make comments for the current patient.

2. Select the exam type

Exam type	Select an exam type for the current patient, including Abdomen, Obstetrics, Gynecology, Cardiology, Vascular, Urology, Small Parts, Pediatrics, Musculoskeletal, Neurology, Orthopedics and others.
Description	Enter manually the information related to the exam type.
Primary Indications	Enter the related information manually.
Secondary Indications	Enter the related information manually.

NOTE:

You must enter the height and weight for the current patient when you select Cardiology as the exam type. **BSA** will be automatically calculated in accordance with the **BSA** set on the **General Settings** menu.

You must enter LMP or EDD for the current patient when you select Obstetrics as the exam type. **AUA** will be automatically calculated.

3. Enter the related operating information

Referring.M.D/Performing.M.D/ Sonographer	Enter manually the name.
Comment	Enter manually the notice or necessary information.

- Click **OK** to save the modifications.

If the last patient exam is not completed, the system will remind you to complete or discontinue the exam. For details, refer to Section 5.3.2 Discontinuing an Exam.

5.1.2 Retrieving Archived Information

You can retrieve the archived information by choosing the **Patient** key > **Patient List** > **Exam Review**.

Press the **Patient** key on the control panel, and then select **Patient List** on the prompt menu.

The screenshot shows the 'Patient Exam List' interface. At the top, there are search filters for Patient ID, Last Name, Age, Date (05/04/2014 to 05/05/2014), First Name, and Sex. A 'Search' button is located to the right of the Patient ID field, and a 'Reset' button is to the right of the Sex field. Below the filters is a table with the following data:

Current Exam	Exam Type	Exam Date/Time	Description	Sonographer	Image Size	Store State
<input type="checkbox"/>	ABD	05/05/2014-16:04:03			0.00M	

On the left side of the screen, there are several buttons: 'New Patient', 'DICOM Q/R', 'DICOM Queue', 'PPS Screen', 'Import/Export' (with a dropdown arrow), 'Import Screen', 'Export Screen', and 'Exit'. At the bottom, there is an 'HD:' label and a row of buttons: 'Resume Exam', 'New Exam', 'Close Exam', 'View Image', 'Delete Exam', 'DICOM Send', and 'DICOM Print'.

Figure 5-2 Exam Review Screen

Perform the following steps to retrieve information.

- Search for the archived information

Enter the search requirements, such as Patient ID, First/Last Name, Sex, Exam Date/Time or Age, and then click **Search** to search for the desired information.

Patient Exam List

Patient ID Last Name Age

Date To First Name Sex

Patient Review

	Patient ID	Patient Name	Birth Date	Sex	Exam Date/Time	Image Size
<input type="checkbox"/>	20140505	Mary	Unknown		05/05/2014-16:04:03	40.82M

Current Exam

Import/Export

HD:

2. Select the desired information
Move the cursor to the desired information, and press the confirm key on the control panel to select it.
3. Exam the desired patient
Click **New Exam** to start a new exam.

5.1.3 Using DICOM Worklist

You can acquire the patient information using the DICOM worklist if the system is configured with the DICOM module. For details, refer to Section 13.4 DICOM Worklist.

5.2 Pausing/Resuming an Exam

5.2.1 Pausing an Exam

1. Press the **Patient** key on the control panel to enter the **New Patient** screen, and then click **Patient List > Exam Review** to enter the **Exam Review** screen.
2. Select the current exam, and then click **Suspend Exam** to pause the exam.

5.2.2 Resume an Exam

1. Press the **Patient** key on the control panel to enter the **New Patient** screen, and then click **Patient List > Patient Review** to enter the **Patient Review** screen.
2. Select the desired patient information, and then click **View** to enter the **Exam Review** screen.
3. Select the desired exam, and then click **Resume Exam** to resume the exam.

5.3 Completing/Discontinuing an Exam

5.3.1 Completing an Exam

1. Press the **End Exam** key on the control panel.

A dialogue box pops up as follows:

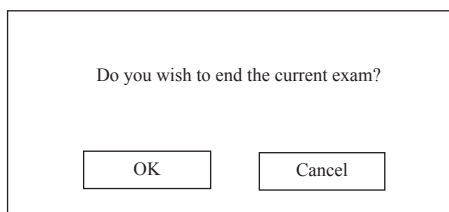

Do you wish to end the current exam?

OK Cancel

2. Click **OK** to end the exam.

5.3.2 Discontinuing an Exam

1. Press the **Patient** key on the control panel to enter the **New Patient** screen and then click **Patient List** to enter the **Patient Exam List** screen.
2. Click **New Patient** to enter the **New Patient** screen. Input the new patient information and click **OK**.

A dialogue box pops up as follows:

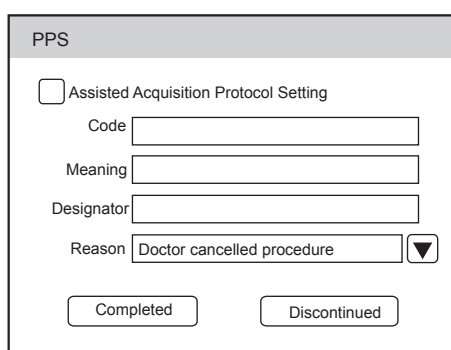

PPS

Assisted Acquisition Protocol Setting

Code

Meaning

Designator

Reason ▼

Completed Discontinued

If you tick **Assisted Acquisition Protocol Setting**, you can send the latest patient information to MPPS after entering the relevant information to code, meaning and designator.

3. Select the reason from the corresponding drop-down list, and then click **Discontinued**.

This page is intentionally left blank.

6 Acquiring Images

You can acquire images by optimizing the relevant parameters for clinical diagnosis.

6.1 Selecting a Probe and an Exam Type

Once the system is started up, the LCD monitor displays the background desktop, the touch screen displays the available probes and the exam types (as shown in Figure 6-1). You can press the **Probe** key on the control panel to return to the following mode when you enter other screens. The system automatically enters the basic screen after you select the desired probe and exam type by tapping the touch screen.

NOTE:

Ensure the probe model and icon displayed on the application mode screen are consistent with the connected probe. If a problem is found, check that the probe is connected to the system firmly. If the problem still exists, please stop using the system immediately and contact the manufacturer.



Figure 6-1 Application Mode Screen

You can also make modifications in an exam type and save them as an application preset for future use. Moreover, the layout of the application mode screen can be modified and factory defaults can be restored.

6.1.1 Customizing A Preset

1. Select the desired probe and exam type.
2. Select an imaging mode and optimize the image.

NOTE:

Parameter optimizing is only available for the current imaging mode.

3. Press the **S** key on the key panel to display the following dialogue box.

Going to
User Pre-Set Menu
Are you sure(Y/N) ?

4. Press the **Y** key to enter the **User preset** screen.

Figure 6-2 User Preset Menu

5. Enter the name of the application preset in the **Exam Name** textbox.
6. Select the department and exam type from the **Exam Type** and **Exam Icon** lists.
7. Click **Create Exam** to create the customized application preset.
If the name of the application preset exists, you can click **Replace Exam** to replace it.

6.1.2 To arrange the presets display

Click **Presets display** to arrange the presets display. The customized application presets, not the system application presets, can be also deleted.

NOTE:

An exam type suffixed with (s) is a system application preset, suffixed with (u) is a customized application preset.

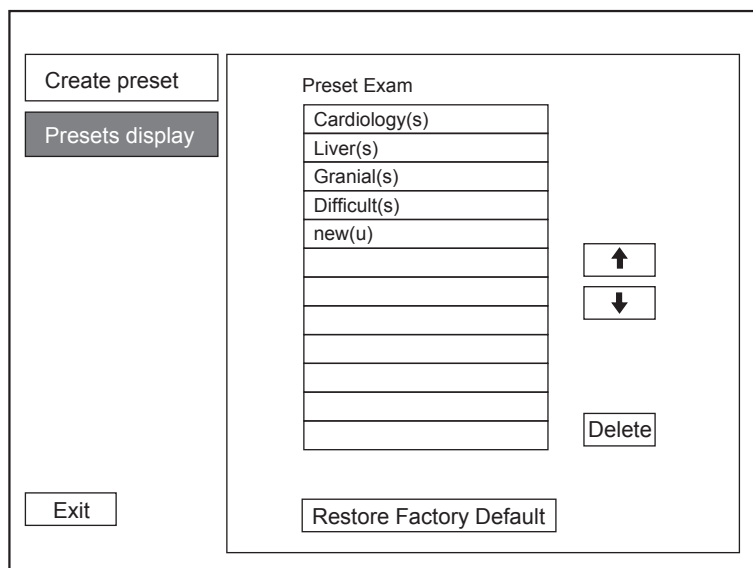

Figure 6-3 Preset Display Menu

- Click one desired application preset, click or to arrange the preset on the application mode screen.
- Click one desired application, click **Delete** > **Yes** to delete the application preset.
- Click **Restore Factory Default** > **Yes** in the pop-up dialogue box to restore factory defaults.

6.2 Acquiring B-Mode Images

B-mode imaging is intended to provide information of anatomical structure of soft tissue.

6.2.1 Entering B Mode

The system enters B mode by default after you select a probe model and an exam type.

You can press the **B** key on the control panel to enter the B mode from other imaging modes.

The basic screen in the B mode is displayed as follows:

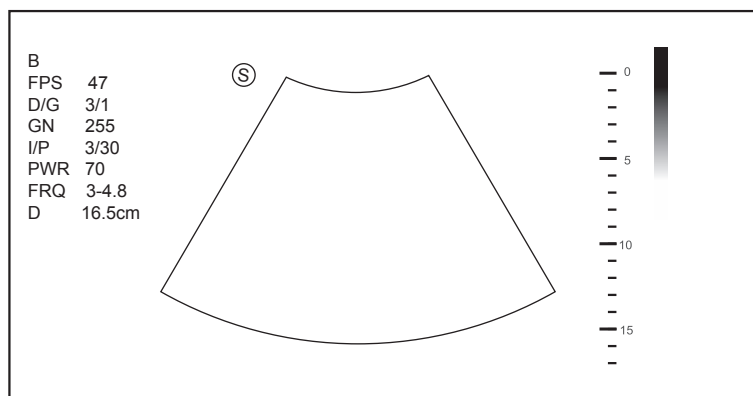

Figure 6-4 B-Mode Imaging Screen

For details on operating the basic screen, refer to Section 2.2.4 Basic Screen.

6.2.2 Optimizing B-Mode Images

The touch screen displays all controls related to the B-mode imaging (as shown in the figure), you can use them to optimize B-mode images.

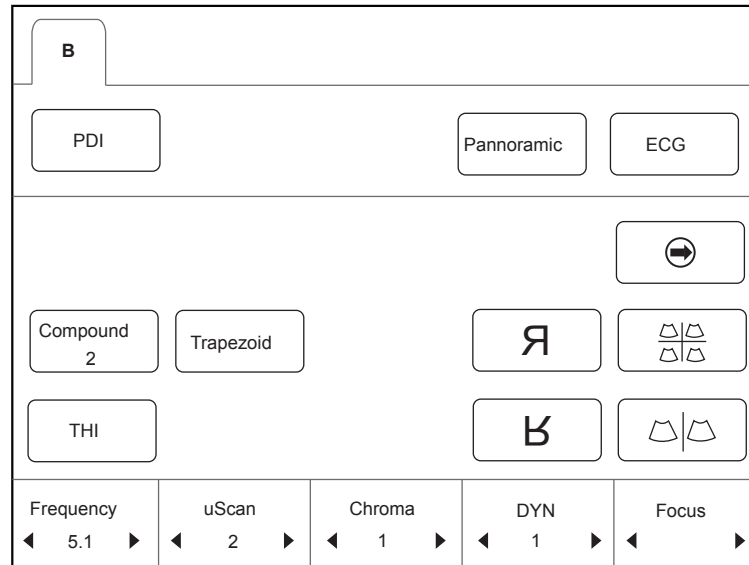



Figure 6-5 B-Mode Imaging Parameters Menu

To optimize the image by using controls in the following instructions:

- Tap the left or right part of an item to adjust the parameter, the value displays at the bottom of the item. You can tap  on the touch screen to turn the current menu to the previous or the next page if it displays over one page.
- Or, rotate the knob on the control panel that is directly below the selected item to adjust the value.

NOTE:

You can adjust all parameters in the real time B mode, but can only adjust **Chroma** and **Gray Map** in the frozen B mode.

■ **Gain**

The B mode gain (2D gain) determines the amplifying factors for the received echoes and the brightness of the ultrasound image. The echoes are amplified with the same gain value regardless of depth.

To adjust the gain:

- Rotate the **B** knob on the control panel clockwise to increase the value.
- Rotate the **B** knob on the control panel anticlockwise to decrease the value.

■ **TGC**

TGC (Time Gain Compensation) is used to adjust the gain that allows compensation for attenuation of the echoes over time (depth). It is adjustable during the real time scan regardless of the imaging mode and display format.

TGC balances the image so that the density of echoes is the same throughout the image.

To adjust TGC:

- Move the desired slider to the left to decrease the value.
- Move the desired slider to the right to increase the value.

NOTE:

- Modifications of TGC values cannot be saved if you shift to use another imaging mode.
- The TGC curve is displayed in the top right corner of the imaging area when you adjust TGC values, and the curve disappears if TGC values are not adjusted for more than 3 seconds.

■ **LGC**

LGC is used to adjust the brightness on the left or right part of the ultrasound image.

To adjust LGC:

- Tap **LGC L** on the touch screen to change the gain on the left part of the ultrasound image.
- Tap **LGC R** on the touch screen to change the gain on the right part of the ultrasound image.

■ **Focal Position/Number/Span**

The focal position/number/span is used to tighten up the beam for a specific area and the focus identified by a red triangle is displayed on the right side of the image.

Focus optimizes the image by increasing the resolution for a specific area.

To adjust the focal position/number/span:

- Tap the left or right part of **Focus** on the touch screen to decrease or increase the depth of focal zone(s).
- Tap the left or right part of **Focal Num** on the touch screen to decrease or increase the number.
- Tap the left or right part of **Focal Span** on the touch screen to decrease or increase the value.

■ **Depth**

Depth is used to adjust the distance over which the B-Mode image is anatomized.

To adjust the depth:

- Rotate the **Depth** knob on the control panel clockwise to increase the depth range of the 2D image and the size of image is reduced to display the entire ultrasound image.
- Rotate the **Depth** knob on the control panel anticlockwise to decrease the depth range of the 2D image and the ultrasound image is magnified.

NOTE:

- The frame rate varies with the depth.
- The range of the scanning depth varies with the probe. D (depth) is displayed in the 2D Image Info area and is represented in unit of cm.

■ **Frequency**

The probe is capable of generating a broadband signal with a certain start frequency and a certain bandwidth. A higher frequency brings about higher resolution and lower penetration.

To adjust the frequency:

- Tap the left part of **Frequency** on the touch screen to decrease the value.
- Tap the right part of **Frequency** on the touch screen to increase the value.

■ **Chroma**

Chroma is used to colorize the gray scale image to enhance the discrimination capability.

To adjust the chroma:

Tap the left or right part of **Chroma** on the touch screen to make a setting.

■ **Compound Imaging**

Compound imaging is used to acquire a series of overlapping image frames from substantially differing spatial directions and combining these images to reduce speckle and improve contrast resolution.

Tap **Compound** on the touch screen to enable or disable the compound imaging function.

■ **Line Density**

Line density refers to the amount of ultrasound beam that makes up the image. Increasing the value of line density improves the resolution and decreases frame rate. Therefore, you have to balance the frame rate and the image quality when adjusting the line density.

A higher line density is useful in obtaining a very high resolution, such as the thyroid or testicles. A lower line density is useful when scanning fetal heart beat and adult cardiac applications.

To adjust the line density

- Tap the left part of **Line Density** on the touch screen to decrease the value.
- Tap the right part of **Line Density** on the touch screen to increase the value.

■ **Persistence**

Persistence is used to average consecutive frames to provide a smoother appearance with less noise. Use lower persistence values for fast-moving organs or tissues and higher persistence values for a smoother appearance.

To adjust the persistence:

- Tap the left part of **Persist** on the touch screen to decrease the value.
- Tap the right part of **Persist** on the touch screen to increase the value.

■ **Dynamic Range**

Dynamic range increases the adjustable range of contrast by enhancing the intensities of parts in the grayscale. It optimizes the ultrasound image texture.

To adjust the dynamic range:

- Tap the left part of **DYN** on the touch screen to decrease the value.
- Tap the right part of **DYN** on the touch screen to increase the value.

■ **Grayscale Curve**

Grayscale curve optimizes the brightness of each pixel in accordance with the corresponding echo. To adjust the grayscale curve:

- Tap the left part of **Gray Map** on the touch screen to decrease the value.
- Tap the right part of **Gray Map** on the touch screen to increase the value.

■ **Adaptive Image Fusion**

Adaptive image fusion provides choices of optimization methods to improve image quality through boundary enhancement, image smoothing and system optimization.

To adjust the adaptive image fusion:

- Tap the left part of **AdaptFusion** on the touch screen to decrease the value.
- Tap the right part of **AdaptFusion** on the touch screen to increase the value.

■ **Sector Width/Angle**

Sector width (for linear probes) or sector angle (for curved and phased array probes) is used to adjust the frame rate. You can adjust the sector width or angle to get more information without moving the probe.

The region of interest of the object can be adjusted after you adjust the sector width or sector angle.

To adjust the sector width/angle:

Tap the left or right part of **Sec. Width** on the touch screen to change the sector width or angle.

■ **Sector Position**

Sector position is used to move or rotate the image.

To adjust the sector position:

Tap the left or right part of **Sector Pos** on the touch screen to move or rotate the image.

■ **Power**

Power is used to select the amount of ultrasound acoustic power produced by the probe. The adjustment range of the power is 1-100%, and $\pm 1\%$ can be adjusted each time. The real time value of the power is displayed in the imaging information area on the basic screen.

To adjust the power:

- Tap the left part of **Power%** on the touch screen to decrease the value.
- Tap the right part of **Power%** on the touch screen to increase the value.

NOTE:

Expose the patient to the lowest practical transmit power level for the shortest possible period of time to achieve a satisfactory diagnosis.

■ **Tissue Acoustic Characteristics**

Tissue acoustic characteristics refer to the speed of ultrasound passing through the tissue. Tissue acoustic characteristics optimize the image used for measurements and calculations. The greater the tissue acoustic characteristics the faster the ultrasound passes through the tissues.

To adjust tissue acoustic characteristics:

- Tap the left part of **Tissue Acou** on the touch screen to decrease the value.
- Tap the right part of **Tissue Acou** on the touch screen to increase the value.

■ **Image Rotation**

You can rotate the image to get more information. Only transvaginal and transrectal exams are available for this feature

To rotate the image:

Tap the left or right part of **Rotation** on the touch screen to rotate the image.

NOTE:

Take notice of the depth calibration displayed at the bottom of the basic screen when the image is rotated by 90° or 270° .

■ **μ Scan**

μ Scan is used to improve the image quality.

To use μ Scan:

- Tap the left part of **μ Scan** on the touch screen to decrease the value.
- Tap the right part of **μ Scan** on the touch screen to increase the value.

NOTE:

Ensure the dongle is inserted before you enable the μ Scan feature.

■ **Trapezoidal Imaging**

Trapezoidal imaging is used to enlarge the imaging area when performing a real time scan by using the linear probes.

To use trapezoidal imaging:

- Tap **Trapezoid** on the touch screen to enable the feature.
- Or, tap **Trapezoid** again on the touch screen to disable the feature.

NOTE:

Only the linear probes are available for trapezoidal imaging.

■ Steer

Steer can be adjusted to change the direction of the acoustic beam when performing a real time scan by using the linear probes.

To adjust the steer:

Tap the left or right part of **Steer** on the touch screen to change the direction of the acoustic beam.

NOTE:

Only the linear probes are capable of using the steer.

6.3 Acquiring Color Flow Images

Color Flow imaging adds the color-coded qualitative information in the B-Mode image. Color Flow imaging is helpful to see the flow, the relevant qualitative information and the flow velocity.

6.3.1 CFM Mode

CFM is a color flow imaging technology which adds the color-coded qualitative information concerning the relative velocity and direction of fluid motion in the B-Mode image.

Perform the following steps to acquire CFM-mode images.

1. Optimize a B-mode image.
2. Press the **CFM** key on the control panel to enter the CFM mode.

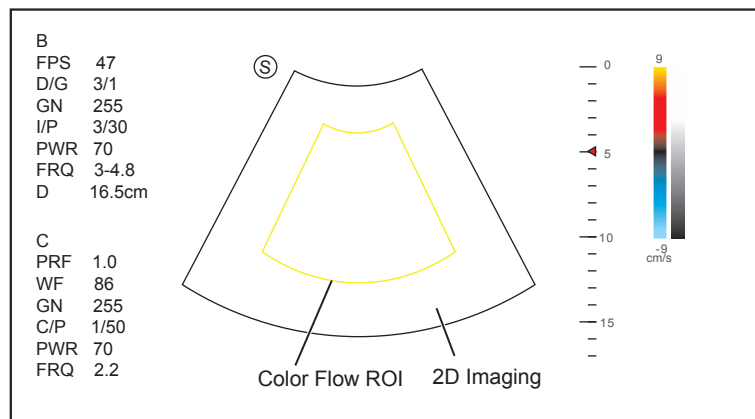

Figure 6-6 CFM-Mode Imaging Screen

3. Adjust color flow ROI.
 - Move the trackball to position color flow ROI.
 - Press the confirm key on the control panel to adjust the size of color flow ROI.
 - Press the confirm key again to reposition color flow ROI.
4. Optimize the CFM-mode image. For details, refer to Section 6.4.3 Optimizing M-Mode Images.
5. Press the **CFM** key again to exit the screen.

6.3.2 PDI Mode

PDI (Power Doppler Imaging) is a color flow imaging technology which adds the flow signal in the CFM-mode image. PDI uses the number and amplitude of red blood cells going through in the flow to create the color-coded imaging. A flow with slow velocity and small rate can be displayed in PDI. Therefore, a flow with a higher sensitivity can be detected without overlaying any flows with high velocity.

The direction of flow, the flow velocity and flow properties cannot be reflected in the PDI-Mode image.

Perform the following steps to acquire PDI-mode images:

1. Optimize a B-mode image.
2. Press the **CFM** key on the control panel, and then tap **PDI** on the touch screen to enter the PDI mode.

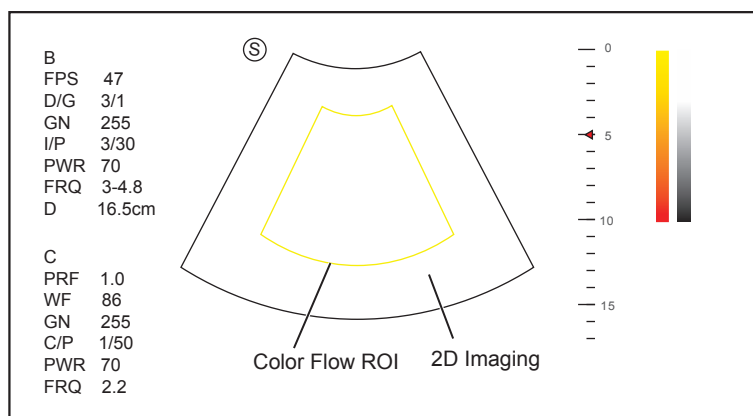

Figure 6-7 PDI-Mode Imaging Screen

3. Adjust color flow ROI.
 - Move the trackball to position color flow ROI.
 - Press the confirm key on the control panel to adjust the size of color flow ROI.
 - Press the confirm key again to reposition color flow ROI.
4. Optimize the PDI-mode image. For details, refer to Section 6.3.4 Optimizing CFM/PDI/TDI Mode Images.
5. Tap **PDI** again to exit the screen.

6.3.3 TDI Mode

NOTE:

TDI imaging is only applied to cardiac applications by using the phased array probes.

TDI (Tissue Doppler Imaging) is a color flow imaging technique which detects the low frequency signal reflected from the cardiac muscle. TDI provides the flow information of velocity and direction for cardiac movement.

TDI uses the low velocity and the high amplitude adjusted from the wall filter to create a color-coded tissue imaging.

Perform the following steps to acquire TDI-mode images.

1. Optimize a B-mode image.
2. Press the **CFM** key on the control panel, and then tap **TDI** on the touch screen to enter the TDI mode.

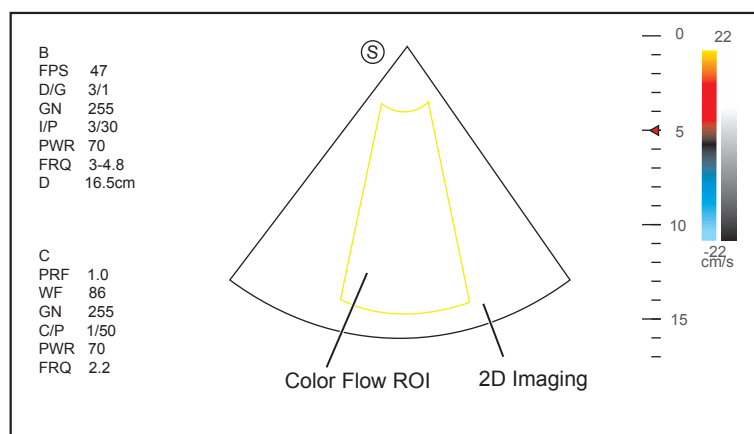

Figure 6-8 TDI-Mode Imaging Screen

3. Adjust color flow ROI.
 - Move the trackball to position color flow ROI.
 - Press the confirm key on the control panel to adjust the size of color flow ROI.
 - Press the confirm key again to reposition color flow ROI.
4. Optimize the TDI-mode image. For details, refer to Section 6.3.4 Optimizing CFM/PDI/TDI Mode Images.
5. Tap **TDI** again to exit the screen.

6.3.4 Optimizing CFM/PDI/TDI Mode Images

The touch screen displays all controls related to the CFM/PDI/TDI-mode imaging (as shown in the figure), you can use them to optimize CFM/PDI/TDI-mode images.

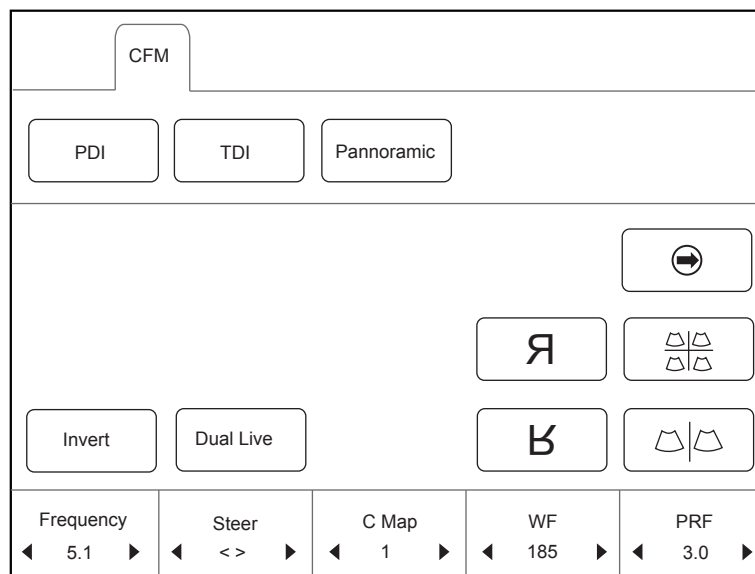



Figure 6-9 Color Flow-Mode Imaging Parameters Menu

To optimize an image by using controls in the following instructions:

- Tap the left or right part of an item to adjust the parameter, the value displays at the bottom of the item. You can tap  on the touch screen to turn the current menu to the previous or the next page if it displays over one page.
- Or, rotate the knob on the control panel that is directly below the selected item to adjust the value.

NOTE:

You can adjust all parameters in a real time CFM/PDI/TDI mode, but can only adjust **Baseline**, **Chroma** and **B Reject** in the frozen CFM/PDI/TDI mode.

■ Gain

Color flow gain optimizes the color flow continuity with less noise interference.

To adjust the gain:

- Rotate the **CFM** knob on the control panel clockwise to increase the value.
- Rotate the **CFM** knob on the control panel anticlockwise to decrease the value.

■ Frequency

Frequency optimizes the penetrability and the sensitivity of the color flow.

To adjust the frequency:

- Tap the left part of **Frequency** on the touch screen to decrease the value.
- Tap the right part of **Frequency** on the touch screen to increase the value.

■ **Wall Filter**

Wall filter is used to filter the low frequency noise from tissues, such as the vascular wall.

To adjust the wall filter:

- Tap the left part of **WF** on the touch screen to decrease the value.
- Tap the right part of **WF** on the touch screen to increase the value.

■ **Pulse Repetition Frequency**

Pulse repetition frequency is used to adjust the velocity scale.

To adjust the pulse repetition frequency:

- Tap the left part of **PRF** on the touch screen to decrease the value.
- Tap the right part of **PRF** on the touch screen to increase the value.

■ **Line Density**

Line density refers to the amount of ultrasound beam that makes up the image. Increasing the value of line density improves the resolution and decreases frame rate. Therefore, you have to balance the frame rate and the image quality when adjusting the line density.

A lower line density is useful in fetal heart beat, adult cardiac applications and in clinical radiology applications. A higher line density is useful in obtaining a very high resolution, such as for the thyroid or testicles.

To adjust the line density:

- Tap the left part of **Line Density** on the touch screen to decrease the value.
- Tap the right part of **Line Density** on the touch screen to increase the value.

■ **Baseline**

Baseline represents the position of zero velocity or frequency. The velocity range in one direction can be increased or decreased by adjusting the baseline.

Baseline is used to eliminate the alias in the color flow imaging, and display higher velocities without reversal of colors.

To adjust the baseline:

- Tap the left part of **Baselines** to move the baseline towards the positive direction.
- Tap the right part of **Baseline** to move the baseline towards the negative direction.

■ **Color Map**

Color map is used to select the method for the color-coding of blood flows.

To adjust the color map:

Tap the left or right part of **C Map** on the touch screen to make the setting.

NOTE:

When **C Map/DPDI** is set to **4** or above in the PDI mode, the system automatically enters the DPDI mode and **DPDI** appears. At this time, you can view the flow direction and velocity.

■ **Persistence**

Persistence is used to average consecutive frames to provide a smoother appearance with less noise. Use lower persistence values for fast-moving organs or tissues and higher persistence values for a smoother appearance.

To adjust the persistence:

- Tap the left part of **Persist** on the touch screen to decrease the value.
- Tap the right part of **Persist** on the touch screen to increase the value.

■ **Sector Width/Angle**

Sector width (for linear probes) or sector angle (for curved and phased array probes) is used to adjust the frame rate. You can adjust the sector width or angle to get more information without moving the probe.

The region of interest of the object can be adjusted after you adjust the sector width or sector angle.

To adjust the sector width/angle:

Tap the left or right part of **Sec. Width** on the touch screen to change the sector width or angle.

■ **Sector Position**

Sector position is used to move or rotate the image.

To adjust the sector position:

Tap the left or right part of **Sector Pos** on the touch screen to move or rotate the image.

■ **Power**

Power is used to select the amount of ultrasound acoustic power produced by the probe. The adjustment range of the power is 0-100%, and $\pm 10\%$ can be adjusted each time. The real time value of the power is displayed in the imaging information area of the basic screen.

To adjust the power:

- Tap the left part of **Power%** on the touch screen to decrease the value.
- Tap the right part of **Power%** on the touch screen to increase the value.

NOTE:

Expose the patient to the lowest practical transmit power level for the shortest possible time to achieve a satisfactory diagnosis.

■ **B Reject**

B Reject is used to set the display priorities of the color and 2D grayscale pixels. A larger B Reject value suppresses more grayscale pixels.

To adjust B Reject:

- Tap the left part of **B Reject** on the touch screen to decrease the value.
- Tap the right part of **B Reject** on the touch screen to increase the value.

■ **Steer**

Steer is used to adjust the angle of CF ROI when performing a real time scan by using the linear probes.

To adjust the steer:

- Tap the left part of **Steer** on the touch screen to rotate the angle clockwise.
- Tap the right part of **Steer** on the touch screen to rotate the angle anticlockwise.

NOTE:

Only the linear probes are available when adjusting steer.

■ **Flow Invert**

Flow invert is used to view blood flow from a different perspective.

When **Invert** is set to **OFF**, red pixels represent flow to the probe; blue pixels represent flow away from the probe.

When **Invert** is set to **ON**, blue pixels represent flow to the probe; red pixels represent flow away from the probe.

To enable or disable the flow invert:

- Tap **Invert** on the touch screen to enable the feature.
- Or, tap **Invert** again on the touch screen to disable the feature.

NOTE:

The color flow and the color map are also inverted when reversing the flow.

6.4 Acquiring M-Mode Images

M mode is generally used with 2D imaging, and is helpful for cardiac applications. In the M mode, you can position the M-line in the 2D image on the anatomy of interest, and then learn about the tissue motion along that line in M-mode trace. In M-mode, y-axis is used to display the position or depth of the tissue, and x-axis is the time scale.

6.4.1 M Mode

The M-line can be only positioned 90° within the ultrasound beam. Therefore, the M mode is used to view motion patterns for regular objects.

Perform the following steps to acquire M-mode images.

1. Optimize a B-mode image.
2. Press the **M** key on the control panel to enter the inactivated B+M mode.

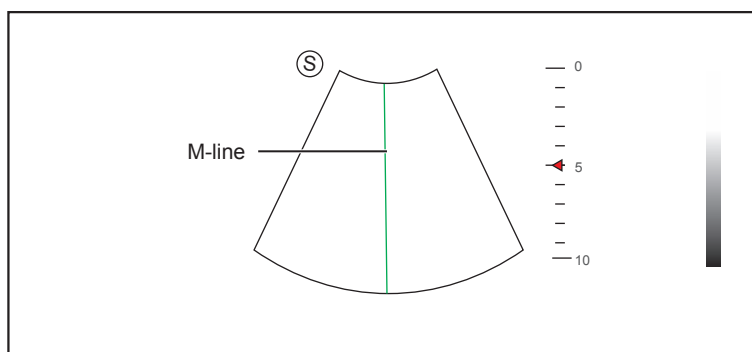

Figure 6-10 Inactivated B+M-Mode Imaging Screen

3. Adjust the M line by using the trackball.
4. Press the **Update** key on the control panel to activate the M mode.

The B-mode image with a M line is displayed at the upper part of the screen and the M-mode image is displayed at the lower part of the screen after being activated, as shown in Figure 6-11.

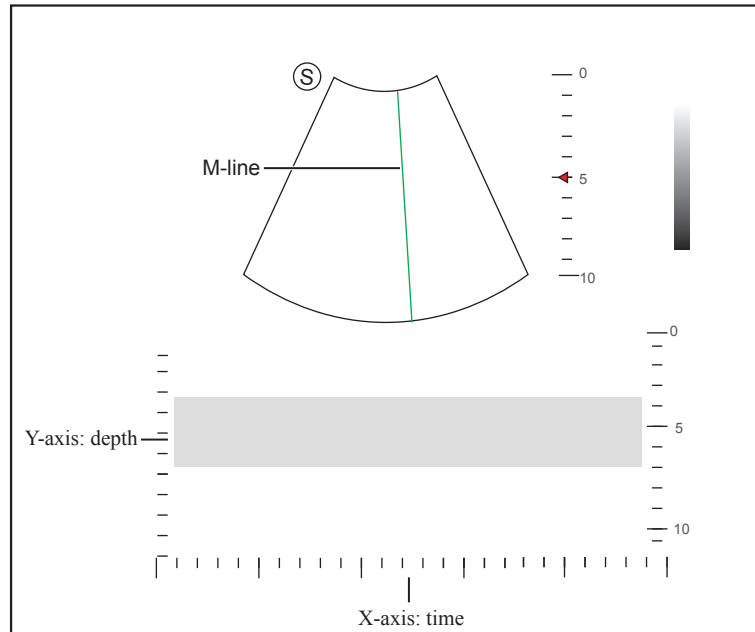

Figure 6-11 M-Mode Imaging Screen

- X-axis is the time scale.
- Y-axis is the depth scale.

NOTE:

Once the M mode is activated, you can move the trackball to stop the M trace and adjust the M line. The system continues tracing if the trackball is idle for more than 0.5s.

5. Optimize M-mode image. For details, refer to Section 6.4.3 Optimizing M-Mode Images.
6. Press the **M** key again to exit the screen.

6.4.2 Anatomical M-Mode

Anatomical M-mode is used for fetal cardiac applications. Anatomical M-mode can be used with phased array probes when performing cardiac exams or convex probes when performing abdominal exams. In the anatomical M-mode, the M-mode cursor can be positioned perpendicular to the anatomical structure and be adjusted 360° even when viewing motion patterns for irregular objects. It is used to study the ventricular function of the heart.

Perform the following steps to acquire anatomical M-mode images.

1. Enter the inactivated B+M mode, tap **Steer M** on the touch screen to set the number of M lines. Multiple M-lines display after selecting the desired number as the following figure shows.

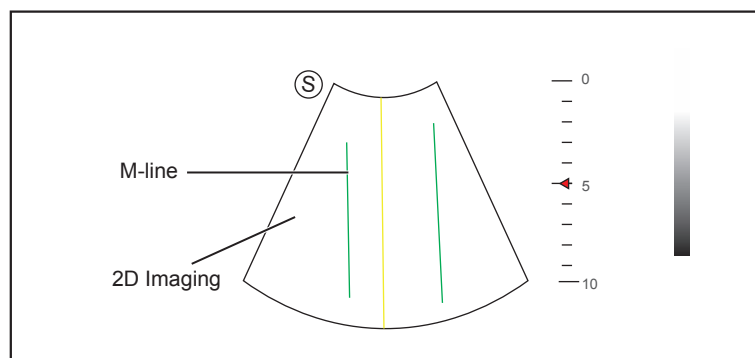

Figure 6-12 Inactivated Anatomical M-Mode Imaging Screen

2. Adjust the position and the angle of M line.
 - Press the confirm key on the control panel to select the desired M line.

- Position the desired M-line by using the trackball.
 - Rotate the **Angle** knob on the control panel to adjust the angle of M line.
3. Press the **Update** key on the control panel to activate the anatomical M-mode.

NOTE:

Once the anatomical M-mode is activated, you can move the trackball to stop the M trace and adjust the M line. The system continues tracing if the trackball is idle for more than 0.5s.

4. Optimize anatomical M-mode images. For details, refer to Section 6.4.3 Optimizing M-Mode Images.
5. Press the **M** key again to exit the screen.

6.4.3 Optimizing M-Mode Images

The touch screen displays all controls related to the M-mode imaging (as shown in the figure), you can use them to optimize M-mode images.

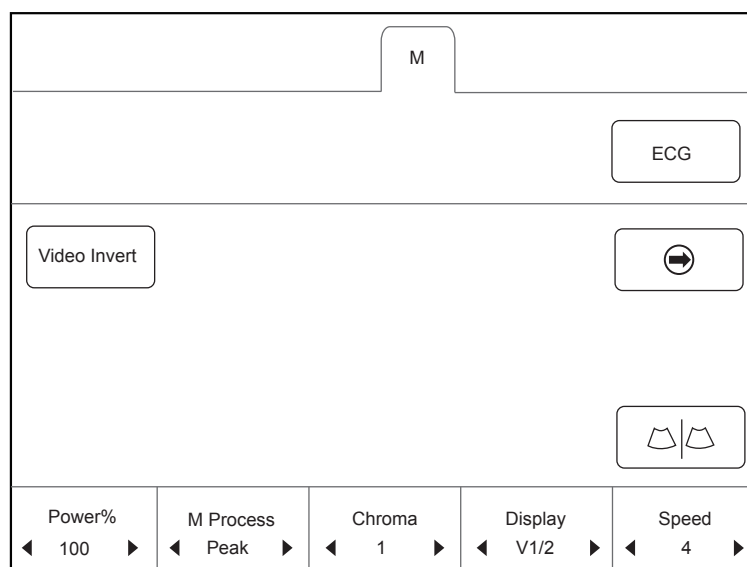



Figure 6-13 M-Mode Imaging Parameters Menu

To optimize an image by using controls in the following instructions:

- Tap the left or right part of an item to adjust the parameter, the value displays at the bottom of the item. You can tap  on the touch screen to turn the current menu to the previous or the next page if it displays over one page.
- Or, rotate the knob on the control panel that is directly below the selected item to adjust the value.

NOTE:

All parameters can be adjusted in a real time B mode, **Chroma** and **Display Format** can also be adjusted in the frozen mode.

■ Gain

M gain controls the overall brightness of the M trace.

To adjust the gain:

- Rotate the **M** knob on the control panel clockwise to increase the value.
- Rotate the **M** knob on the control panel anticlockwise to decrease the value.

■ M Process

M process is used to set the processing method for the M trace display.

To set M process:

Tap the left or right part of **M Process** to adjust the setting.

■ **Sweep Speed**

Sweep speed is used to set the sweep speed of the M trace. A faster speed is more suitable to view the motion.

To adjust the sweep speed:

- Tap the left part of **Speed** to decrease the value.
- Tap the right part of **Speed** to increase the value.

■ **Chroma**

Chroma is used to colorize the gray scale image to enhance the discrimination capability.

To adjust the chroma:

Tap the left or right part of **Chroma** on the touch screen to adjust the setting.

■ **Display Format**

Display format is used to view the image better.

To set the display format:

Tap the left or right part of **Display** on the touch screen to adjust the setting.

■ **Power**

Power is used to select the amount of ultrasound acoustic power produced by the probe. The adjustment range of the power is 30%-100%, and $\pm 10\%$ can be adjusted each time. The real time value of the power is displayed in the imaging information area on the basic screen.

To adjust the power:

- Tap the left part of **Power%** on the touch screen to decrease the value.
- Tap the right part of **Power%** on the touch screen to increase the value.

NOTE:

Expose the patient to the lowest practical transmit power level for the shortest possible time to achieve a satisfactory diagnosis.

■ **Video Invert**

Video invert is used to invert the M trace display related to brightness.

To enable or disable the video invert:

- Tap **Video Invert** on the touch screen to enable the feature.
- Or, tap **Video Invert** again on the touch screen to disable the feature.

6.5 Acquiring Spectral Doppler Images

Spectral Doppler imaging is intended to provide measurement data concerning the velocity, the direction, and the category of the arterial or vein flow. It contributes a more accurate qualitative analysis than the color flow imaging.

Spectral Doppler includes Pulsed Wave Doppler (PW) mode and Continuous Wave Doppler (CW) mode.

6.5.1 PW Mode

Pulsed Wave Doppler (PW) is a Doppler mode that measures velocity in a PW sample volume and displays that information in a spectral trace with audio output. PW includes conventional PW and High Pulse Repetition Frequency (HPRF). PW Doppler can be combined with the B mode for rapidly selecting the anatomical site for PW Doppler examination. The site where PW Doppler data is derived appears graphically on the B-Mode image.

Perform the following steps to acquire PW-mode images

1. Optimize a B-mode image.
2. Press the **PW** key on the control panel to enter the inactivated B+PW mode 1.

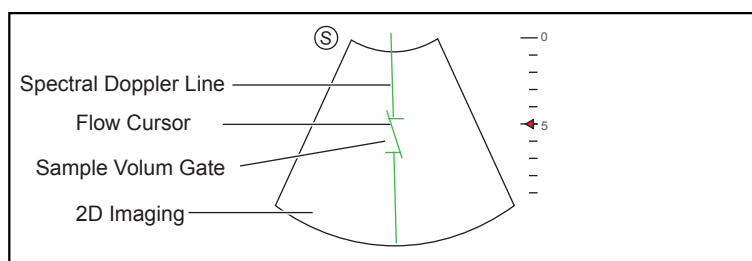

Figure 6-14 Inactivated B+PW Mode 1 Imaging Screen

- The spectral Doppler line and the sample volume gate are used to locate the qualitative analysis on the image.
 - The flow cursor needs to be adjusted parallel to the flow when measuring the velocity.
3. Adjust the position and angle of the spectral Doppler line.
 - Position the sample volume gate on the spectral Doppler line by moving the trackball upwards or downwards.
 - Adjust the angle of the spectral Doppler line by moving the trackball to the left or the right.
 4. Adjust the sample volume gate.
 - Adjust the size of the sample volume gate by using the trackball.
 - Rotate the **Angle** knob on the control panel to adjust the angle of the flow cursor.
 5. Press the **Update** key on the control panel to activate the PW mode.

The PW spectrum is displayed at the lower part of the screen after being activated, as shown in Figure 6-15.

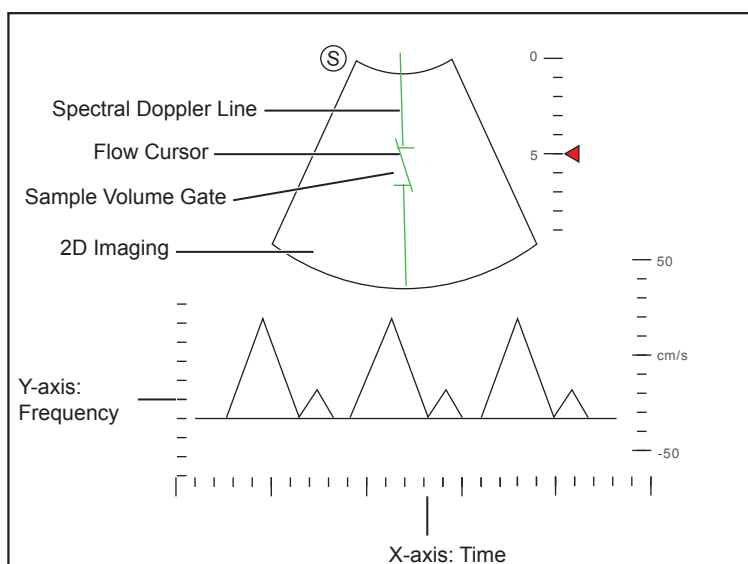

Figure 6-15 PW-Mode Imaging Screen

- X-axis is the time scale.
- Y-axis is Doppler frequency scale, including positive and negative indicators.

Rotate the **Audio** knob on the control panel to adjust the audio volume.

NOTE:

Once the PW-mode is activated, you can move the trackball to stop the Doppler trace and adjust the sample volume gate. The system continues tracing if the trackball is idle for more than 0.5s.

- Optimize the PW-mode image. For details, refer to Section 6.5.3 Optimizing Spectral Doppler Images.

If needed, press the **Update** key on the control panel to enter the inactivated B+PW mode 2, the following screen appears.

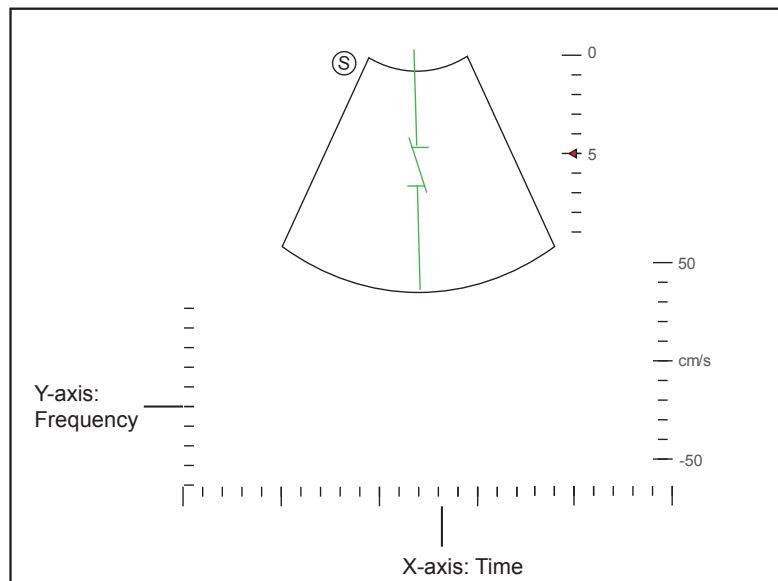

Figure 6-16 Inactivated B+PW Mode 2 Imaging Screen

You can also adjust the position and angle of spectral Doppler line, the size of sample volume gate, and the direction of the flow cursor.

- Press the **PW** key again to exit the screen.

6.5.2 CW Mode

Continuous Wave Doppler (CW) uses continuously transmitted and received ultrasound energy to generate a spectral display. CW Doppler is used to measure a high velocity, the highest velocity at a specific site, but no aliasing is created.

Perform the following steps to acquire CW-mode images.

- Optimize a B-mode image.
- Press the **CW** key on the control panel to enter the inactivated B+CW mode 1.

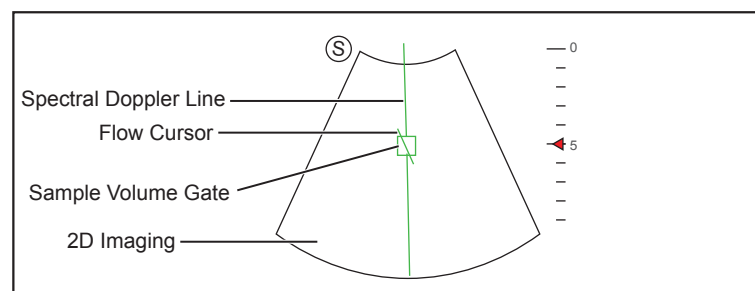

Figure 6-17 Inactivated B+CW-Mode 1 Imaging Screen

- The spectral Doppler line and the sample volume gate are used to locate the qualitative analysis on the image.
 - The flow cursor needs to be adjusted parallel to the flow when measuring the velocity.
- Adjust the position and angle of the spectral Doppler line.
 - Position the sample volume gate on the spectral Doppler line by moving the trackball upwards or downwards.

- Adjust the angle of the spectral Doppler line by moving the trackball to the left or the right.
- 4. Rotate the **Angle** knob on the control panel to adjust the angle of the flow cursor.
- 5. Press the **Update** key on the control panel to activate the CW mode.

The CW spectrum is displayed at the lower part of the screen after being activated, as shown in Figure 6-18.

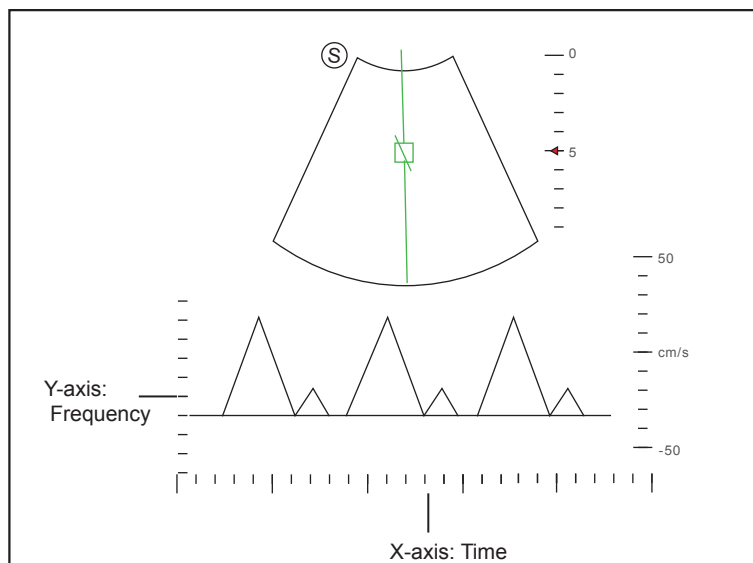

Figure 6-18 CW-Mode Imaging Screen

- X-axis is the time scale.
- Y-axis is Doppler frequency scale, including positive and negative indicators.

Rotate the **Audio** knob on the control panel to adjust the audio volume.

NOTE:

Once the CW-mode is activated, you can move the trackball to stop the Doppler trace and adjust the sample volume gate. The system continues tracing if the trackball is idle for more than 0.5s.

6. Optimize the CW-mode image. For details, refer to Section 6.5.3 Optimizing Spectral Doppler Images.

If needed, press the **Update** key on the control panel to enter the inactivated B+CW mode 2, the following screen appears.

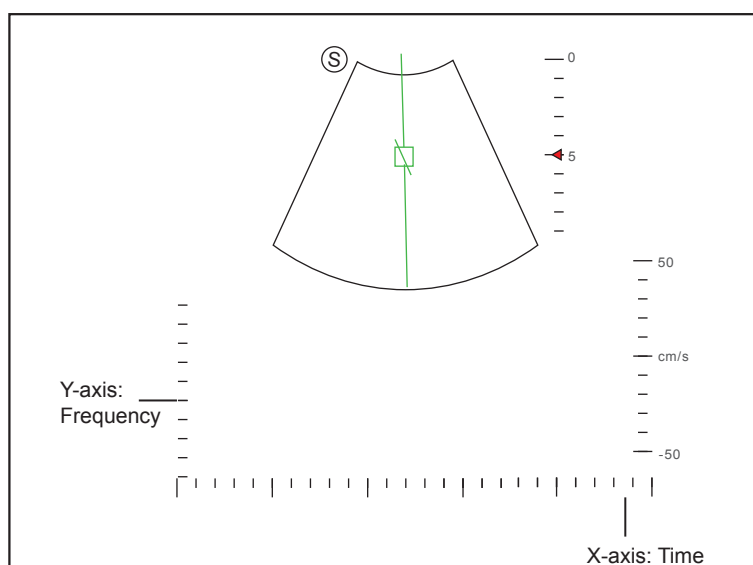

Figure 6-19 Inactivated B+CW Mode 2 Imaging Screen

You can also adjust the position and angle of spectral Doppler line, and the direction of the flow cursor.

- Press the **CW** key again to exit the screen.

6.5.3 Optimizing Spectral Doppler Images

The touch screen displays all controls related to the PW/CW-mode imaging (as shown in the figure), you can use them to optimize PW/CW-mode images.

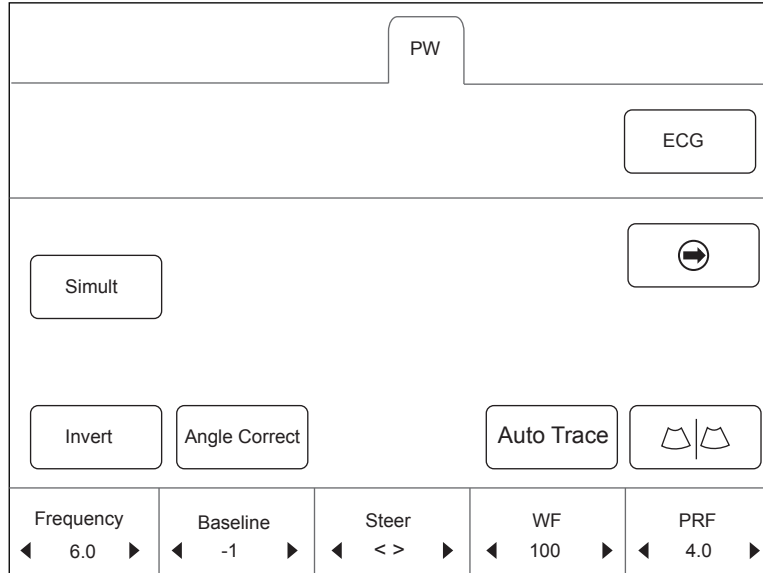



Figure 6-20 Spectral Doppler Mode Imaging Parameters Menu

To optimize an image by using controls in the following instructions:

- Tap the left or right part of an item to adjust the parameter, the value displays at the bottom of the item. You can tap  on the touch screen to turn the current menu to the previous or the next page if it displays over one page.
- Or, rotate the knob on the control panel that is directly below the selected item to adjust the value.

NOTE:

You can adjust all parameters in the real time PW/CW mode, but can only adjust **Baseline**, **Chroma** and **Display Format** in the frozen PW/CW mode.

■ Gain

PW/CW gain is used to adjust the gain of the spectrum map. Increasing the gain will brighten the image, allowing you to see more received signals with less noise.

To adjust the gain:

- Rotate the **PW** or **CW** knob on the control panel clockwise to increase the value.
- Rotate the **PW** or **CW** knob on the control panel anticlockwise to decrease the value.

■ Pulse Repetition Frequency

Pulse repetition frequency is used to adjust the velocity scale, filter the unnecessary low frequency signal or the disturbance made by non-flow movements, such as breath, heart beat or sweeps of the probe.

The range of PRF value varies with the probe model and the exam type.

To adjust the pulse repetition frequency:

- Tap the left part of **PRF** on the touch screen to decrease the value.
- Tap the right part of **PRF** on the touch screen to increase the value.

NOTE:

The value of wall filter is also changed when adjusting PRF.

■ High Pulse Repetition Frequency

Once HPRF is enabled, besides the original sample volume gate, one or more sample volume gates appear at shallower positions on the 2D image. The unnecessary low frequency signal or the disturbances made by non-flow movements, such as breath, heart beat or sweeps of the probe will be filtered.

To enable the High Pulse Repetition Frequency:

Tap the right part of **PRF** to increase the value continuously, HPRF is automatically enabled when a certain value is reached.

NOTE:

The linear probes are not available for HPRF.

■ Baseline

Baseline represents the position of zero velocity or frequency. The velocity range in one direction can be increased or decreased by adjusting the baseline.

Baseline is used to unwraps the alias during color flow imaging, and display higher velocities without reversal of colors.

To adjust the baseline:

- Tap the left part of **Baseline** to move the baseline towards the positive direction, and the velocity range in the color map varies with the adjustment.
- Tap the right part of **Baseline** to move the baseline towards the negative direction, and the velocity range in the color map varies with the adjustment.

■ Wall Filter

Wall filter is used to filter the low frequency noise from tissues, such as the vascular wall.

To adjust the wall filter:

- Tap the left part of **WF** on the touch screen to decrease the value.
- Tap the right part of **WF** on the touch screen to increase the value.

■ Frequency

The probe is capable of generating a broadband signal with a certain frequency and bandwidth. The frequency optimizes the edges when scanning deeper locations with Doppler imaging.

To adjust the frequency:

- Tap the left part of **Frequency** on the touch screen to decrease the value.
- Tap the right part of **Frequency** on the touch screen to increase the value.

■ Sweep Speed

Sweep speed is used to set the sweep speed of the Doppler trace. The refresh speeds of the time scale and the frequency scale vary with the sweep speed.

To adjust the sweep speed:

- Tap the left part of **Speed** to decrease the value.
- Tap the right part of **Speed** to increase the value.

■ **Power**

Power is used to select the amount of ultrasound acoustic power produced by the probe. The adjustment range of the power is 30%-100%, and $\pm 10\%$ can be adjusted each time. The real time value of the power is displayed in the image parameter area on the basic screen.

To adjust the power:

- Tap the left part of **Power%** on the touch screen to decrease the value.
- Tap the right part of **Power%** on the touch screen to increase the value.

NOTE:

Expose the patient to the lowest practical transmit power level for the shortest possible time to achieve a satisfactory diagnosis.

■ **Chroma**

Chroma is used to colorize the gray scale image to enhance the discrimination capability.

To adjust the chroma:

Tap the left or right part of **Chroma** on the touch screen to choose a color scheme.

■ **Dynamic Range**

Dynamic range increases the adjustable range of contrast by enhancing the intensities of parts in the grayscale. It is useful for optimizing the ultrasound image texture.

To adjust the dynamic range:

- Tap the left part of **DYN** on the touch screen to decrease the value.
- Tap the right part of **DYN** on the touch screen to increase the value.

■ **Display Format**

Display format is used to view the image better.

To set the display format:

Tap the left or right part of **Display** on the touch screen to adjust the setting.

■ **Flow Invert**

Flow invert is used to view the flow velocity from a different perspective.

To enable or disable the flow invert:

- Tap **Invert** on the touch screen to enable the feature, and **INVERT** appears on the top right corner of the image.
- Or, tap **Invert** again on the touch screen to disable the feature, and **INVERT** disappears from the display.

■ **Video Invert**

Video invert is used to view the background of the spectral display from a different perspective.

To enable or disable the flow invert:

- Tap **Video Invert** on the touch screen to enable the feature, and a brighter background appears.
- Or, tap **Video Invert** again on the touch screen to disable the feature, and a darker background appears.

■ **Angle Correction**

Angle correction is used to adjust the angle of the flow cursor in the PW mode.

To adjust the angle:

- Rotate the **Angle** knob on the control panel to adjust the angle.

- Or, tap the left or right part of **AngleCorrect** on the touch screen to adjust the angle.

NOTE:

You only need to set it when performing measurements related to velocity.

- **Simult**

Simult is used to synchronously display two real time scans in the 2D and the PW modes.

To enable or disable the feature:

Tap **Simult** in the activated PW mode or in the inactivated B+PW mode 2, the two real time scans in the 2D and the PW modes are displayed.

NOTE:

Simult is only available in the PW mode.

6.6 Acquiring Triplex-Mode Images

The triplex mode is overlapped by three different imaging modes, and can be applied to view the image. The triplex mode includes B+CFM/TDI+M, B+CFM/PDI/TDI+PW and B+CFM/PDI+CW.

6.6.1 B+CFM/TDI +M

NOTE:

Only the phased array probes are available for B+CFM/TDI+M.

Perform the following steps to acquire the image.

1. Optimize a CFM/TDI mode image.
2. Press the **M** key on the control panel to enter the inactivated B+CFM/TDI+M mode.

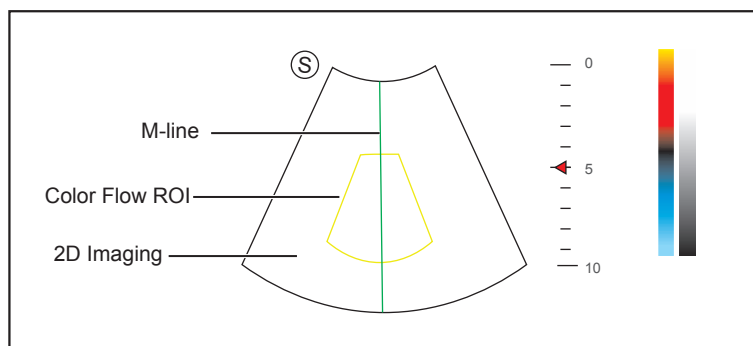

Figure 6-21 Inactivated B+CFM/TDI +M-Mode Imaging Screen

3. Adjust the M line by using the trackball.
4. Press the **Update** key on the control panel to activate the M mode.
The basic screen displays the following after being activated.

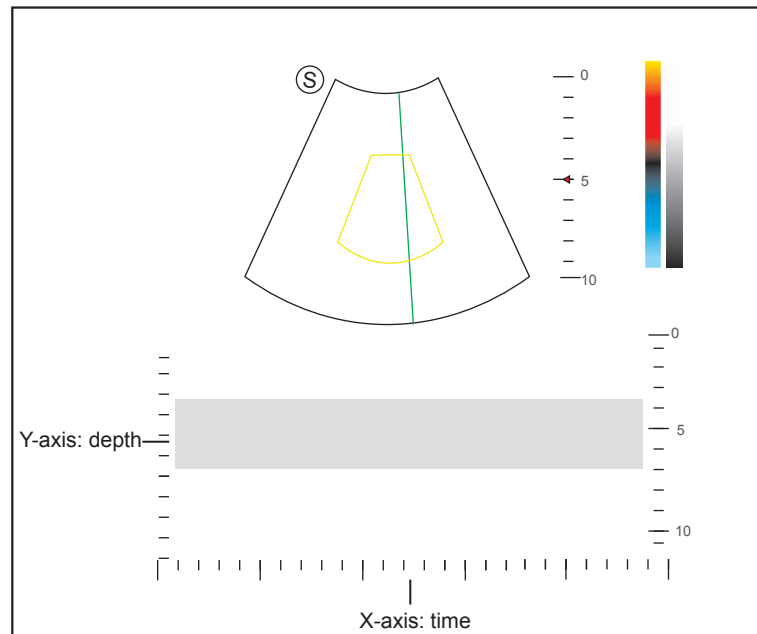

Figure 6-22 B+CFM/TDI +M-Mode Imaging Screen

5. Optimize the M-mode image. For details, refer to Section 6.4.3 Optimizing M-Mode Images.
6. Press the **M** key again to exit the screen.

6.6.2 B+CFM/PDI/TDI +PW

Perform the following steps to acquire the image.

1. Optimize a CFM/PDI/TDI-mode image.
2. Press the **PW** key on the control panel to enter the inactivated B+CFM/PDI/TDI+PW mode 1.

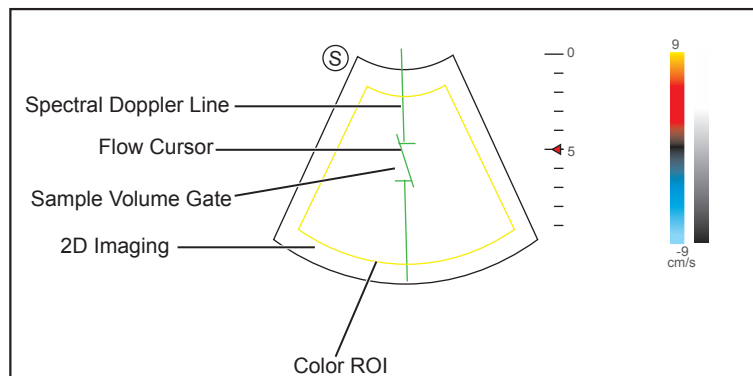

Figure 6-23 Inactivated B+CFM/PDI/TDI+PW-Mode 1 Imaging Screen

3. Adjust the position and angle of the spectral Doppler line.
 - Position the sample volume gate on the spectral Doppler line by moving the trackball upwards or downwards.
 - Adjust the angle of the spectral Doppler line by moving the trackball to the left or the right.
4. Adjust the sample volume gate.
 - Press the confirm key on the control panel to adjust the size of the sample volume gate.
 - Rotate the **Angle** knob on the control panel to adjust the angle of the flow cursor.
5. Press the **Update** key on the control panel to activate the PW mode.

The PW spectrum is displayed at the lower part of the screen after being activated, as shown Figure 6-24.

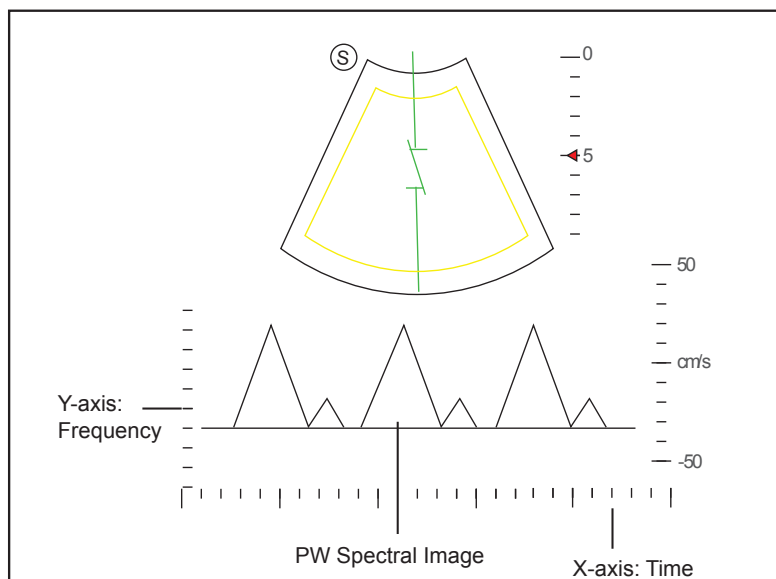

Figure 6-24 B+CFM/PDI/TDI+PW-Mode Imaging Screen

Rotate the **Audio** knob on the control panel to adjust the audio volume.

NOTE:

Once the PW-mode is activated, you can move the trackball to stop the Doppler trace and adjust the sample volume gate. The system continues tracing if the trackball is idle for more than 0.5s.

- Optimize the PW-mode image. For details, refer to Section 6.5.3 Optimizing Spectral Doppler Images.

If needed, press the **Update** key on the control panel to enter the inactivated CFM/PDI/TDI+PW mode 2, the following screen appears.

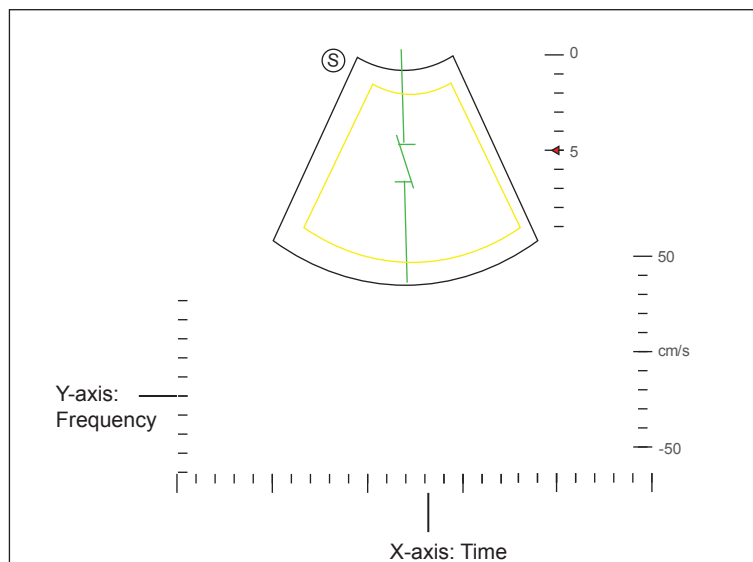

Figure 6-25 Inactivated CFM/PDI/TDI+PW Mode 2 Imaging Screen

You can also adjust the position and angle of spectral Doppler line, the size of the sample volume gate, and the direction of the flow cursor.

- Press the **PW** key again to exit the screen.

6.6.3 B+CFM/PDI+CW

For details, refer to Section 6.6.2 B+CFM/PDI/TDI +PW.

This page is intentionally left blank.

7 Elastography Imaging

As an adjunct technique for clinical practice, the elastography determines if an area of tissue is hard or soft when compared with its surroundings. Furthermore, it provides an elastography image to discover tumors (stiffer than the surrounding tissue). The elastography image displays a range of map shades from the softest tissue in the image to the stiffest in a given field of view.

Elastography is used in ultrasound diagnosis for small parts applications, such as breast and thyroid examinations.

NOTE:

The following description uses small parts examination performed with the L741 probe as an example.

7.1 Acquiring Elastography Images

Perform the following steps to acquire the elastography image.

1. Select L741 and Small Parts as the desired probe and exam type, the system automatically enters the real-time B mode.
2. Acquire a high quality B-mode image.
3. Tap **Elasto** on the touch screen to enter the elastography imaging.

As Figure 7-1 shows, the elastography image is displayed on the left and a real-time B-mode image is displayed on the right.

Tap  on the touch screen to enter the single or dual split screen display.

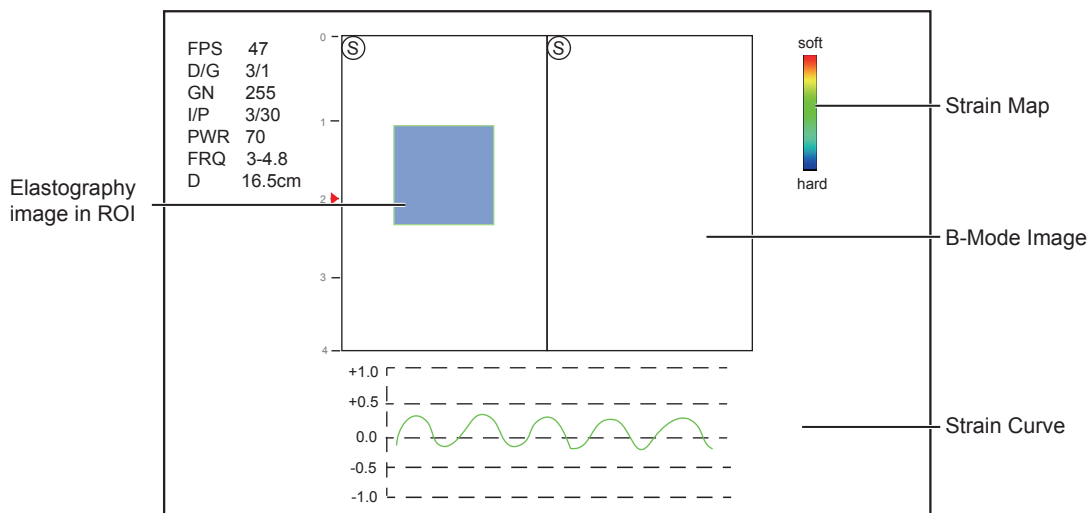

Figure 7-1 Elastography Imaging Screen

- Elastography map provides color information for tissue stiffness.
- B-mode image is compared with the elastography image for a real-time assessment.
- Strain curve displays the compressing frequency and its corresponding displacement. X axis is the frame number, Y axis is the displacement of the corresponding frame.
- The Elastography image in the ROI is translucent and overlapped on the B-mode image.

4. Hold the probe perpendicular to the target lesion, and compress it regularly.

Operation Concerns:

- Ensure the compression is applied perpendicularly, and all parts of the target lesion are compressed uniformly.
- Ensure the compression is a dynamic intermittent force, i.e. alternate tension with relaxation, which could keep the distorted tissue back to normal status. If the distorted tissue is not relaxed, the tissue cannot be distorted and the elastography imaging cannot be performed.
- The compressing frequency is recommended to be 1.5-3 times per second. Lift the probe up after each pressure, and ensure the probe is not away from the target lesion.
- The absolute value of positive and negative maximums on strain curves should be 0.5-1. If the absolute value is below 0.5 or over 1, the compression is too hard or too low for correct elastography results.

5. Adjust the elastography ROI.

To acquire accurate tissue stiffness information, you are recommended to adjust the elastography ROI to two times of the target lesion

- Move the trackball to position elastography ROI.
- Press the confirm key on the control panel to adjust the size of elastography ROI.
- Press the confirm key to reposition elastography ROI.

6. Optimize the elastography image. For details, refer to Section 7.2 Optimizing Elastography Images.

7. Tap **Elasto** again to exit the screen.

7.2 Optimizing Elastography Images

The touch screen displays all controls related to the elastography imaging (as shown in the figure), you can use them to optimize elastography images.

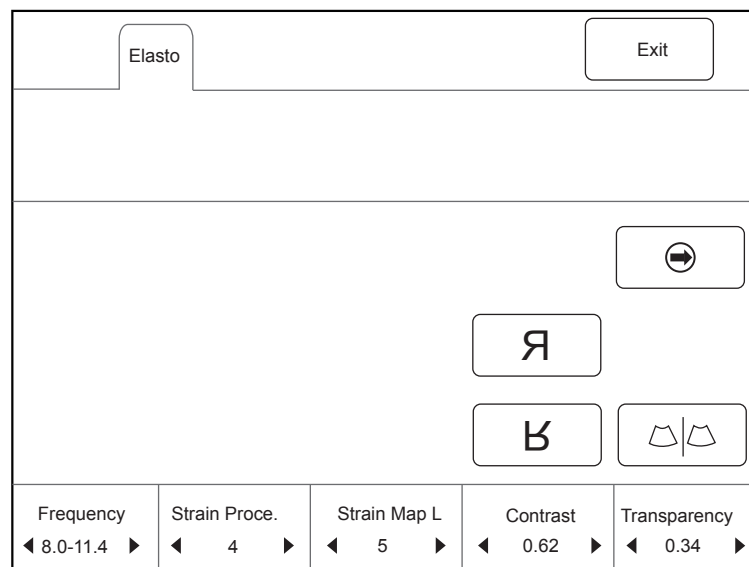



Figure 7-2 Elastography Imaging Parameters Menu

You can tap  on the touch screen to turn the current menu to the previous or the next page if it displays over one page.

To optimize the image by using controls in the following instructions:

- Tap the left or right part of an item to adjust the parameter, the value displays at the bottom of the item.
- Or, rotate the knob on the control panel that is directly below the selected item to adjust the value.

NOTE:

All parameters can only be adjusted in real-time elastography imaging.

7.2.1 Strain Map

Strains map allows you to select and apply a color map to the elastography or B-mode image on the left or right during the elastography imaging. The image will be displayed with the use of 256-color mapping for each pixel according to the degree of strain using a scale from red (highest strain, softest), green (average strain, intermediate), to blue (no strain, hardest).

To adjust the strain map:

- Tap the left or right part of **Strain Map L** to choose the color scheme for the elastography image.
- Tap the left part of **Strain Map R** to remove from or choose the color scheme for the B-mode image.
- Tap the right part of **Strain Map R** to apply or choose the color scheme for the B-mode image.

7.2.2 Strain Process

Strain process is used to set relative parameters of the elastography algorithm, the elastography image varies with this setting.

To adjust the strain process:

- Tap the left part of **Strain Proce.** on the touch screen to decrease the value.
- Tap the right part of **Strain Proce.** on the touch screen to increase the value.

7.2.3 Transparency

Transparency allows you to bring out the tissue behind the color data.

To adjust the transparency:

- Tap the left part of **Transparency** on the touch screen to decrease the value.
- Tap the right part of **Transparency** on the touch screen to increase the value.

7.2.4 Contrast

Contrast enhances the color contrast for more accurate tissue stiffness information.

To adjust the contrast:

- Tap the left part of **Contrast** on the touch screen to decrease the value.
- Tap the right part of **Contrast** on the touch screen to increase the value.

7.2.5 Persistence

Persistence is used to average consecutive frames to provide a smoother appearance with less noise. Use lower persistence values for fast-moving organs or tissues and higher persistence values for a smoother appearance.

To adjust the persistence:

- Tap the left part of **Persist** on the touch screen to decrease the value.
- Tap the right part of **Persist** on the touch screen to increase the value.

7.2.6 Frequency

The transducer is capable of generating a broadband signal with a certain start frequency and a certain bandwidth. A higher frequency brings about higher resolution and lower penetration.

To adjust the frequency:

- Tap the left part of **Frequency** on the touch screen to decrease the value.
- Tap the right part of **Frequency** on the touch screen to increase the value.

7.3 Working with Elastography Images

You can work with the elastography images by using the features in the frozen mode, such as cine review, annotations, data storage or measurement. For details, refer to Section 11.4 Using Cine, Section 11.5 Annotations and Body Marks, 12 Managing Images/Data and the relevant sections in the advanced user manual.

8 Contrast Imaging

Contrast imaging is used in conjunction with ultrasound contrast agents to increase the acoustic impedance difference between blood flow and tissue, improve 2D imaging resolution for myocardial, liver, kidney and cephalic applications and enhance Doppler signals for blood flow. Contrast imaging helps in observing normal and abnormal tissue and blood flow.

NOTE:

Contrast imaging is only available performed with linear or curved probes.



WARNING Contrast imaging is only used in conjunction with commercial contrast agents legally approved by laws and local regulations. Do not use the contrast agent not got any legal permits or official registrations. The manufacturer would not guarantee the safety and reliability for any contrast agents.

The following description uses a liver examination performed with the C353 probe as an example.

8.1 Entering Contrast Imaging

Perform the following steps to enter the contrast imaging.

1. Select C353 and Abdomen as the desired probe and exam type, the system automatically enters the real-time B mode.
2. Position the target tissue in the B+Color mode, and observe the blood flow.
3. Return to the B mode, tap **Contrast** on the touch screen to enter the contrast imaging.

As Figure 8-1 shows, a real-time contrast image is displayed on the left and a B-mode in real-time mode is displayed on the right.

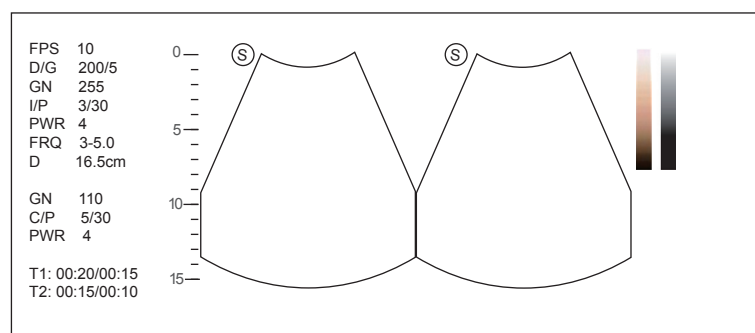

Figure 8-1 Contrast Imaging Screen

- Tap **Single View** to enter the single display.
- Tap **Dual View** to enter the dual split display.
- Tap **Exit** to exit the imaging screen.

8.2 Optimizing Contrast Images

The touch screen displays all controls related to the contrast imaging (as shown in the figure), you can use them to optimize contrast images.

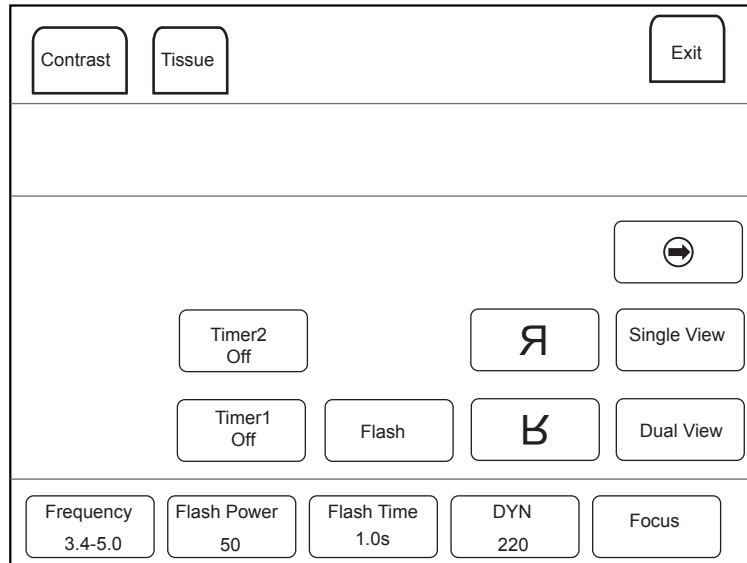



Figure 8-2 Contrast Imaging Parameters Menu

You can tap  on the touch screen to turn the current menu to the previous or the next page if it displays over one page.

You can also tap **Contrast** or **Tissue** to make settings of the relevant tab.

To optimize the image by using controls in the following instructions:

- Tap the left or right part of an item to adjust the parameter, the value displays at the bottom of the item.
- Or, rotate the knob on the control panel that is directly below the selected item to adjust the value.

NOTE:

All parameters can only be adjusted in a real-time contrast imaging, but **F By F**, **Cine Speed**, **Chroma** and **Gray Map** can also be adjusted in the frozen mode. Only settings of **Gain**, **Flash Power** and **Flash Time** are detailed in this section, for settings of other parameters, refer to 6.2.2 Optimizing B-Mode Images.

8.2.1 Gain

Contrast imaging gain determines the amplifying factors for the received echoes and the brightness of the ultrasound image. The echoes are amplified with the same gain value regardless of depth.

To adjust the gain:

- Rotate the **CFM** knob to adjust the gain of contrast image.
- Rotate the **B** knob to adjust the gain of THI image.

8.2.2 Flash Power

Flash power allows you to select the maximum transmit power level produced by the transducer in the contrast imaging.

To adjust the flash power:

Tap the left or right part of **Flash Power** to make the setting.

8.2.3 Flash Time

Flash time allows you to set the transmit duration of high-voltage pulse.

To adjust the time:

Tap the left or right part of **Flash Time** to make the setting.

8.3 Acquiring Contrast Images

Perform the following steps to acquire contrast images.

1. Inject contrast agents, and tap **Timer1** or **Timer2** on the touch screen to start timing.

Once the timer is started, **Timer** displays on the screen and the system starts timing for contrast agent duration.

 - Press the **Save** (📁) key on the control panel to set the start frame for cine review. Press the **Save** (📁) key again to set the end frame of cine. The corresponding thumbnails for the stored cine appears in the clipboard.
 - Press the **Freeze** key on the control panel to freeze the image. Freezing time is displayed on the screen, and the timer continues timing. Press the **Freeze** key again to return to the real-time mode.
 - Tap **Timer1** or **Timer2** again to exit.
2. Observe and record circulation and perfusion of the target tissue.

If the second perfusion is needed, tap **Flash** on the touch screen to enter the flash contrast imaging and destruct microbubbles. Tap **Flash** repeatedly to destruct the residual microbubbles. After the destruction, inject contrast agents and observe the perfusion of the target tissue.
3. Press the **Freeze** key to freeze the image.

8.4 Working with Contrast Images

You can work with the contrast images by using the features in the frozen mode, such as cine review, annotations, data storage or measurement. For details, refer to Section 11.4 Using Cine, Section 11.5 Annotations and Body Marks, 12 Managing Images/Data and the relevant sections in the advanced user manual.

You can also get more information about blood flow characteristics through observing TIC curves. TIC curve indicates the contrast agent intensity variation with duration. To make a TIC analysis, you should position ROI (8 at most), and then make a detailed analysis of the contrast agent intensity variation with duration.

Perform the following steps to make a TIC analysis.

1. Tap **TIC** in the frozen mode to enter the TIC analysis screen.
2. Position one or more ROI on the contrast image.
 - Tap **Ellipse** on the touch screen, position a ROI by performing an ellipse measurement.
 - Tap **Trace** on the touch screen, position a ROI by performing an auto-trace measurement.

Once you position a ROI, the corresponding TIC curve is displayed on the bottom, colors of TIC curve and ROI are consistent.

As Figure 8-3 shows, all relevant parameters are displayed on the top right part of the screen.

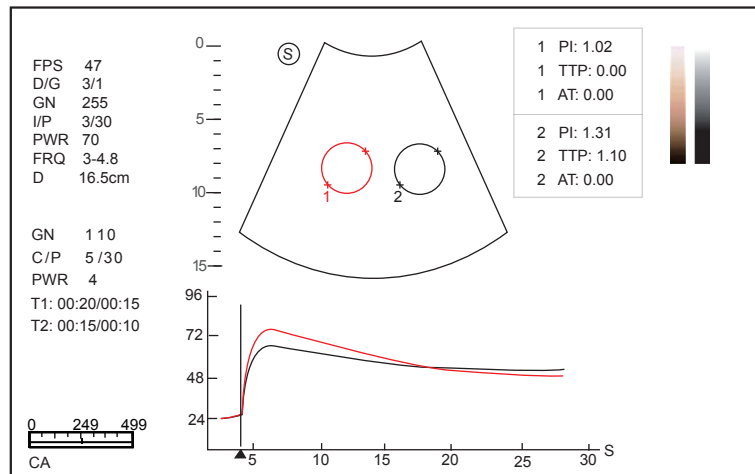

Figure 8-3 TIC Analysis Screen

- X axis is the contrast agent duration, represents in s.
- Y axis represents the contrast agent intensity, represents in dB.

You can press the **Clear** key on the control panel to delete all ROIs and TIC curves.

3. Analyze TIC curves for more information about circulation and perfusion.

Use the trackball to observe contrast images frame by frame, the indication line on the corresponding TIC varies with the frame.

4. Tap **Exit** on the touch screen to return to the contrast imaging screen.

9 3D Imaging

3D imaging allows you to see width, height and depth of the anatomical structure. 3D imaging can be performed by all probes, but the quality of the images is closely related to 2D imaging.

3D imaging mainly applies to obstetric exams, and can be used to see the three dimensional volume image of the internal organs or a fetus.

9.1 Acquiring 3D Images

The following description uses 3D imaging performed with the VC6-2 probe as an example.

Perform the following steps to acquire 3D images.

1. Enter the patient information, select the VC6-2 probe and an exam type (such as the obstetric exam used throughout this chapter) to enter the B mode.
2. Optimize imaging parameters in the B mode.
3. Apply adequate gel on the patient.
4. Acquire a B-mode image of high quality.
5. Tap **3D/4D** on the touch screen to enter the inactivated 4D mode.

NOTE:

- When using a volume probe, you can set the default inactivated 3D or 4D mode. For details, refer to Section 4.1.4 Defined-Key Settings.
 - When using a non-volume probe, you should press the **Freeze** key and tap **FreeHand 3D** to enter the inactivated 3D mode.
6. Tap the **3D** tab to enter the inactivated 3D mode.

The 2D imaging with ROI and sample line is displayed in the inactivated 3D mode, only the data in ROI is acquired for 3D imaging.

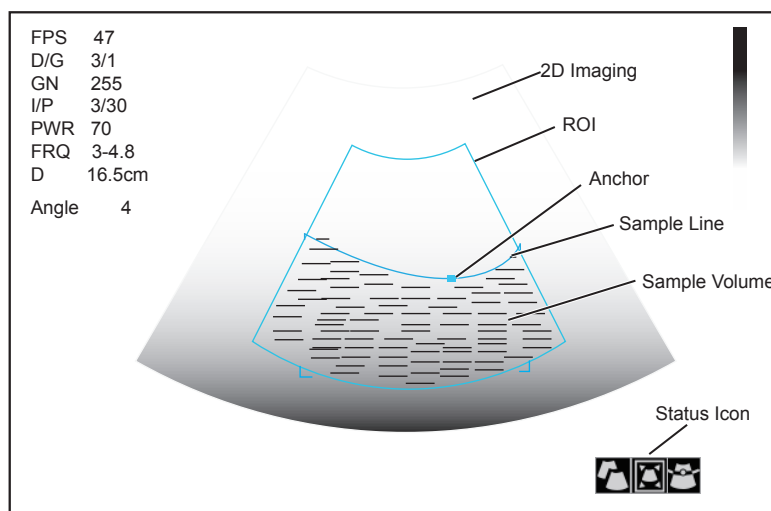





Figure 9-1 Inactivated 3D Imaging Screen

7. Adjust ROI and sample line.



You can press the confirm key to select the desired status icon.

- If  is highlighted, use the trackball to position the ROI.
- If  is highlighted, use the trackball to resize the ROI.
- If  is highlighted, adjust the sample line by positioning the anchor with the trackball.

8. Set the user mode, focus position, image quality and sweep angle.

- Tap an item under **User Mode** to select a user mode.
- Tap the Left/Right part of **Sweep Angle** to adjust the sweep angle of probe.
- Tap the left or right part of **Focus** to decrease or increase the depth of focal zone.
- Tap the left or right part of **Image Quality** to adjust quality of images.

9. Display the 3D imaging in the following instructions.

- Tap ,  or , tap **Start** or press the **Freeze** key to display the 3D imaging in a full, dual or quad display. The system automatically enters the 3D imaging in a quad display by default.
- Tap **1**, **2** or **4** on the key panel of the touch screen to display the 3D imaging in a full, dual or quad display.

The imaging area of the screen is divided into 3 reference images and a 3D image by default.

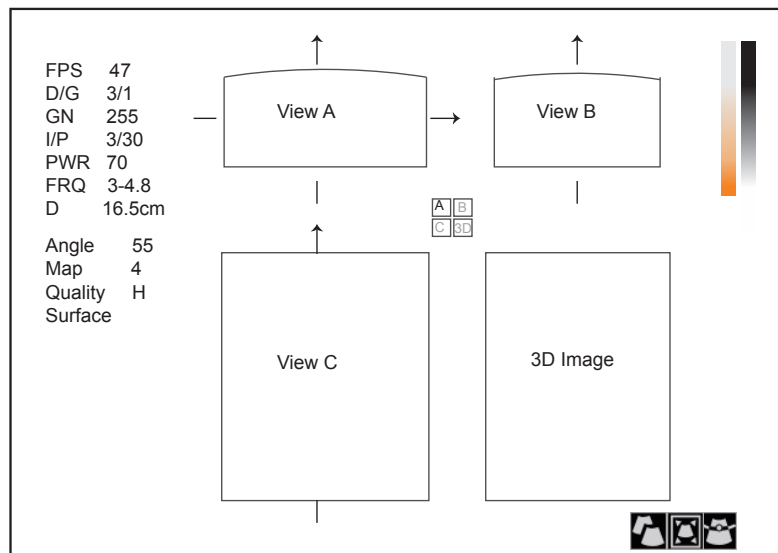

Figure 9-2 3D Imaging Screen

As the above figure shows,

- View A on the top left shows the image on the X-axis.
- View B on the top right shows the image on the Y-axis.
- View C on the bottom left shows the image on the Z-axis.
- The image on the bottom right shows the 3D image.

As Figure 9-3 shows, the touch screen displays all controls related to the 3D imaging.

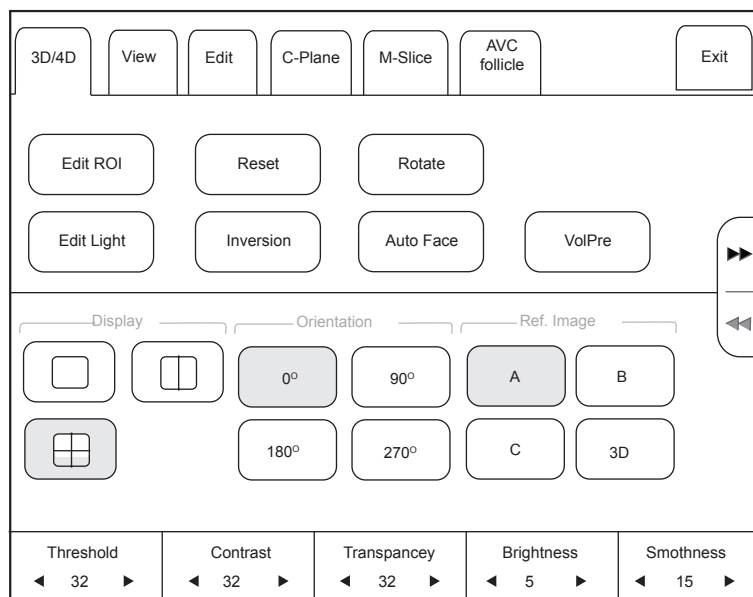

Figure 9-3 3D Imaging Parameters Menu

- Tap ►► or ◀◀ to turn the current menu to the previous or the next page.
- Tap **VolPre** or press the **Freeze** key to return to the inactivated 3D mode.
- Tap **Exit** on the **3D/4D** tab to return to the real-time B mode. Tap **Exit** on other tabs to switch to the **3D/4D** tab.

9.2 Working with 3D Images

You can review, optimize or save 3D images.

You can also tap **Edit ROI** on the touch screen to freeze three reference images, and then use the trackball to view the 3D image for better observation; tap **Edit ROI** again to unfreeze three reference images.

9.2.1 Adjusting ROI

You can crop the 3D image by adjusting the ROI on the reference images.

Perform the following steps to adjust ROI.

1. Tap **3D/4D** > **A**, **B** or **C** to select the desired reference image.
2. Adjust images inside the ROI on the reference image.

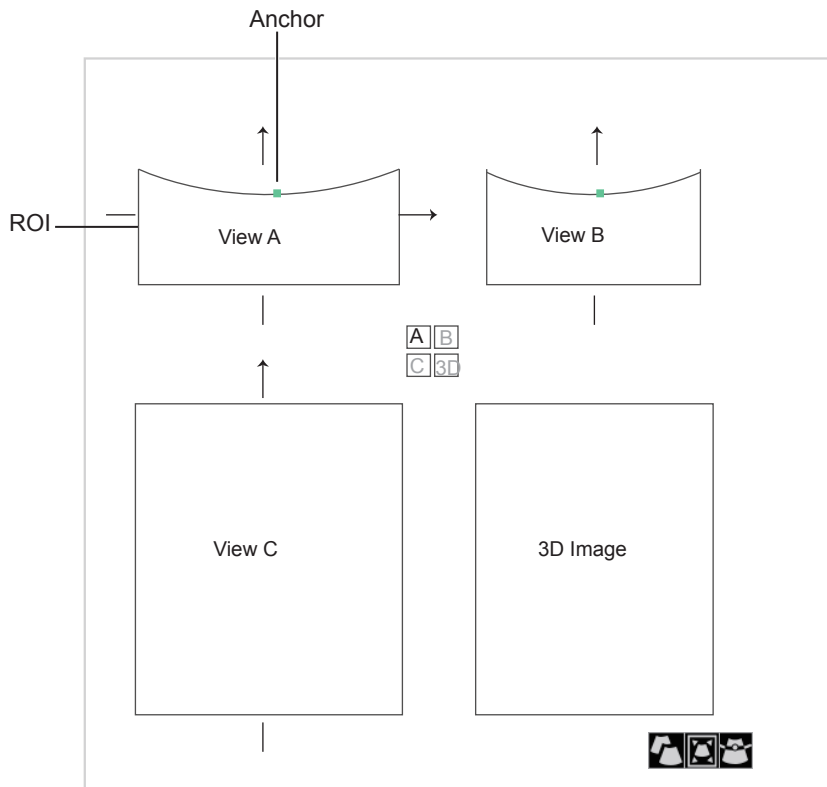





Figure 9-4 Cropping Review Screen



You can press the confirm key to select the desired status icon.

- If  is highlighted, use the trackball to position the ROI.
- If  is highlighted, use the trackball to resize the ROI.
- If  is highlighted, adjust the sample line by positioning the anchor with the trackball.

Only images inside the ROI are generated to a 3D image, and the real-time 3D image is also displayed when cropping reviews.

9.2.2 Setting Display Format

To setting the display format in the following instructions.

- Tap **3D/4D**, tap ,  or  to enter the full, dual or quad split screen display mode.
- Tap **1**, **2** or **4** on the key panel of the touch screen to enter the full, dual or quad split screen display mode.

9.2.3 Using Auto Face

Fetal face can be automatically recognized by using the auto face feature even if fetal hands, placenta, umbilical cord or other uterus adnexa block your view.

In the frozen mode, tap Auto Face to clear obstacles. Tap Auto Face again to restore the original image.

9.2.4 Setting Render Mode

Tap **3D/4D** > an item under **Render Mode** to select a render mode.

- **Surface** displays gray values of the surface structures. It is suitable for observing the contour (eyes, ears, nose, lip) of fetus.
- **Grad. Light** displays the surface structures in a strengthened light intensity. It is suitable for observing the contour (eyes, ears, nose, lip) of fetus.
- **Skeleton** displays the highest intensity of echo along the ultrasound beam. It is suitable for observing the spinal column and skeleton of the fetus.

- **Transp. Min** displays the minimum gray value within ROI. It is suitable for observing dark areas (vessels, cysts).
- **X-Ray** displays all gray values within ROI. It is suitable for observing tissue or tissue mass.
- **S-Depth** displays color signals of the echoes along the ultrasound beam. It is suitable for observing the contour (eyes, ears, nose, lip) of fetus.
- **S-Live** displays sides of the surface structures in a strengthen light intensity. The icon  appears at the lower-right corner of the screen when **S-Live** mode is selected. It is suitable for observing 3D surface.





9.2.5 Cropping Reviews

You can crop 3D image by tracing its border, adjusting a box or using the eraser.

■ Cropping Reviews with Trace

You can crop 3D image by tracing its border to remove areas outside the area of interest. This feature is suitable for cropping irregular reviews.

Perform the following steps to crop a review.

1. Tap **Edit** >  or  to enable the feature.
 - Tap  to remove all data inside the traced area from the image.
 - Tap  to remove all data outside the traced area from the image.
2. Move the cursor on the image by using the trackball, press the confirm key on the control panel, and then trace the border of the object.





3. Press the confirm key to acquire the desired image.

In the following figure,  is enabled.







NOTE:

- Tapping  can restore the review.
- Taping  can undo the last cut.
- Taping  can redo the last cut.



■ Cropping Reviews by the Box

You can crop 3D image by adjusting a box on the 3D image to remove irrelevant areas from interest area. This feature is suitable for cropping regular reviews.

Perform the following steps to crop a review.

1. Tap **Edit** >  or  to enable the feature.
 - Tap  to remove all data outside from the image.
 - Tap  to remove all data inside from the image.
2. Move the cursor to the image by using the trackball, press the confirm key on the control panel, and then trace the border of the object.
3. Press the confirm key to acquire the desired image.



NOTE:

- Tapping  can restore the review.
- Tapping  can undo the last cut.
- Tapping  can redo the last cut.



■ **Cropping Reviews by the Eraser**

You can crop 3D image by using the eraser to remove irrelevant areas from interest area. This feature is suitable for cropping irregular reviews.

Perform the following steps to crop a review.

1. Tap **Edit** >  (big eraser) or  (small eraser) to enable the feature.
2. Move the cursor on the image by using the trackball, press the confirm key on the control panel, and then use the eraser to remove irrelevant areas.
3. Press the confirm key to acquire the desired image.

NOTE:

- Tapping  can restore the review.
- Tapping  can undo the last cut.
- Tapping  can redo the last cut.

9.2.6 Moving/Rotating/Magnifying Images

■ **To Select an Image**

Tap **3D/4D** > **A, B, C** or **3D** to select the desired image.

■ **To Move Images**

Tap **View**, tap the left/right part of **Move L/R** to move images left/right.

Tap **View**, tap the left/right part of **Move U/D** to move images up/down.

Rotate the **CFM** knob on the control panel to move images Left/Right.

■ **To Rotate Images**

- Tap **3D/4D** or **Edit** and then tap **Rotate** to rotate images by using the trackball.
- Tap **3D/4D** > **0°/45°/90°/180°/270°/360°** to set the rotation angle, all images are automatically rotated from the original position to the position of 1/2 preset angle, and then rotated in a reversed way in turns.
- Tap **View** > **Top, Bottom, Left, Right, Front** or **Back** to rotate all images.
- Tap **View**, tap the left/right part of **Rotate X, Rotate Y** or **Rotate Z** to manually rotate all images along x, y or z axis.
- Rotate the **M/CW/PW** knob to manually rotate all images along x, y or z axis.
- Tap **View** > **0°/90°/180°/270°** to rotate all images in a preset angle.
- Tap **3D/4D** > **3D** to rotate the 3D image by using the trackball.

- **To Zoom Out/In All Images**

Press the **Zoom** key on the control panel to zoom in or zoom out the image by rotating the **Depth** knob. Meanwhile, a size multiplier is displayed in the information area of the basic screen.

- **To Inverse Images**

Tap **3D/4D > Inversion** to inverse the gray values of anechoic structures on 3D image.

9.2.7 Optimizing 3D Image

- **To Choose the Color**

- Tap **3D/4D**, tap the left/right part of **3D Chroma** to choose the color scheme for the 3D image.
 - Tap **3D/4D**, tap the left/right part of **B Chroma** to choose the color scheme for reference images.
 - Tap **M-Slice**, tap the left/right part of **B Chroma** to choose the color scheme for slices
- The grayscale or color map on the top right of the imaging area varies with this setting.

- **To Set the Contrast and Transparency**

- Tap **3D/4D**, tap the left/right part of **Contrast** to set the contrast of the 3D image.
- Tap **3D/4D**, tap the left/right part of **Transparency** to set the transparency of the 3D image.

- **To Set Threshold, Smoothness and Brightness**

- Tap **3D/4D**, tap the Left/Right part of **Threshold** to set the threshold value of the 3D image.
- Tap **3D/4D**, tap the Left/Right part of **Smoothness** to set the smoothness of the 3D image.
- Tap **3D/4D**, tap the Left/Right part of **Brightness** to set the brightness of the 3D image.

- **To Adjust the Light Position**

- In S-Live mode, tap **Edit Light** on the touch screen, locate the light position using the trackball, then press the confirm button on the control panel.
- You can also tap the Left/Right part of **Light Pos.** to set the light position. The light icon at the lower-right of the screen will change accordingly, and the shined area of 3D image will be brightened.

9.2.8 Observing Reference Image by the Plane

You can observe reviews by using the plane.

Perform the following steps to observe a review.

1. Tap **C-Plane** to enable this feature.

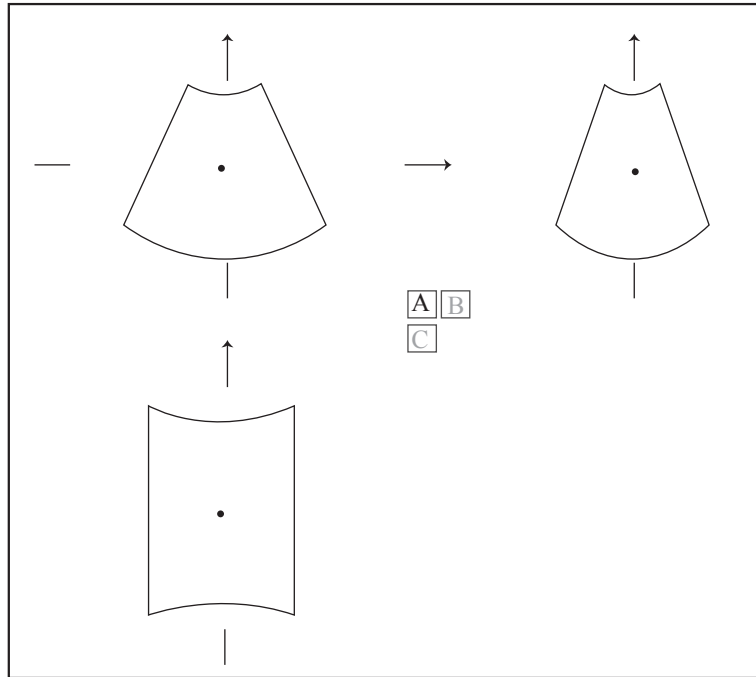

2. Tap **A**, **B** or **C** to select the desired reference image, and then tap

A	B
---	---

,

A	C
---	---

,

B	C
---	---

 or

A	B	C
---	---	---

 to select the display format.
3. Move the cursor on the desired reference image by using the trackball, and observe reference images on the screen.

9.2.9 Observing Reviews by the Slice

You can observe reviews by using two or more slices. For example, each layer of an irregular tumor can be observed by applying this feature.

Perform the following steps to observe a review.

1. Tap **M-Slice** > **A**, **B**, **C** or **3D** to select the desired image.
After the selection, the desired image on the corresponding axis is displayed on the screen.
2. Tap **1*2**, **2*2**, **3*3**, **3*4**, **4*4** or **5*5** to set the slice number.
In the following figure, 9-slice imaging on the X axis is taken as an example.

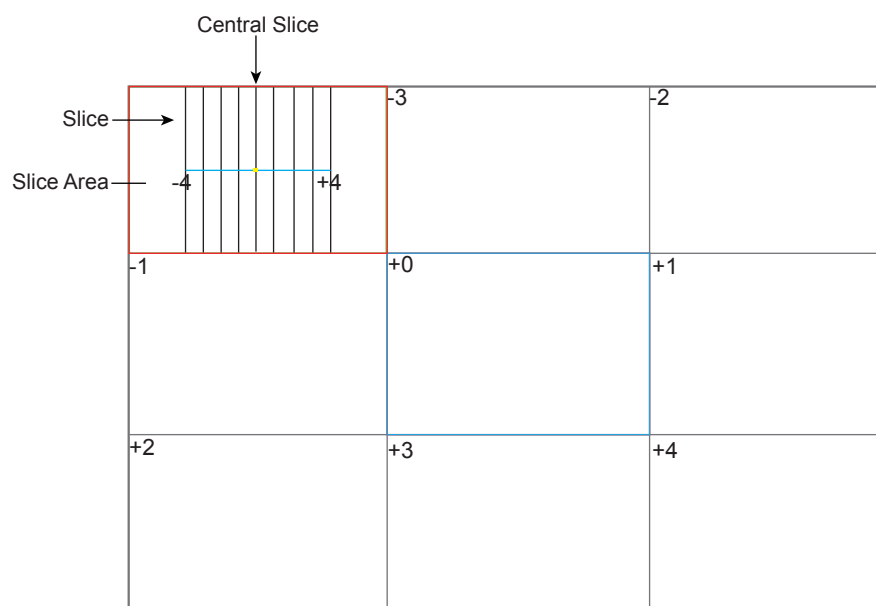

Figure 9-5 Multi-Slice Imaging Screen

Nine slices and the corresponding number are displayed on the slice imaging. The middle full line is the central slice in the current slice axis, and it is numbered as 0.

Except for the central slice, the other eight slices are indicated by the number at the top left corner of the slice and are displayed on the screen. Tap the Left/Right part of **Display** to move all the slices in the slice area left or right.

Move the cursor on the one slice by using the trackball to select it.

To adjust the slice position/slice distance/slice number,

- Tap the Left/Right part of **Adjust Pos.** to fine-tune the selected slice position.
- Tap the Left/Right part of **Distance** to adjust the distance among the slices. The span and content vary with this setting.
- Tap the Left/Right part of **Slice Num** to decrease or increase the number of slices.

After adjusting, the slice position, slice distance, the slice number, and the corresponding image of the slice will change accordingly.

9.2.10 Setting the Scan Mode

Set **Scan Mode** in accordance with your preference.

Tap **Linear** or **Sector** to set the sweep mode.

NOTE:

This setting is only effective when entering 3D imaging from a frozen B mode image.

9.2.11 Adjusting ZAngle/ZScale

The image may be distorted if you perform the scan too quickly by using the probe. To acquire a vivid image, you can adjust the value of **ZAngle/ZScale** before the scan.

- If **Scan Mode** is set to **Sector**, you can adjust the sweep angle when performing the scan by the probe. Tapping the left/right part of **ZAngle** can adjust the angle.
- If **Scan Mode** is set to **Linear**, you can adjust the sweep span when performing the scan by the probe. Tapping the left/right part of **ZScale** can adjust the scale.

NOTE:

This setting is only effective when entering 3D imaging from a frozen B mode image.

9.2.12 Restoring the Image

Tap **3D/4D > Reset** to restore the relevant settings.

9.2.13 Customizing Presets

You can modify parameters, adjust sample volume or ROI in the 3D mode and save them as the application preset for future use. Moreover, the customized layout of the application mode screen can be modified and restored to factory defaults.

NOTE:

Only the volume probes are capable of this feature.

For details, refer to Section 6.1 Selecting a Probe and an Exam Type.

The application presets can be displayed as options of the **User Mode** item in the inactivated 3D mode.

9.2.14 Performing Follicle Auto-Measurement

Tap **AVC Follicle > Left Ovary/Right Ovary** to automatically measure the number and the volume of follicles, and the position of follicles is displayed on three reference images and 3D image.

10 4D Imaging

4D imaging enables the display of real time 3D anatomical structures.

4D imaging can only be performed by compatible volume probes. 4D imaging adds the dimension of “movement” to a 3D image by providing continuous, real-time displays of internal organs or fetus. 3D imaging provides single frame images, while 4D imaging provides continuous, high volume acquisition of 3D images.

The following description uses the fetal imaging as an example, the other imaging options are as the same.

10.1 Acquiring 4D Images

The following description uses 4D imaging performed with the VC6-2 probe as an example.

10.1.1 Entering the Real-Time 4D Imaging

Perform the following steps as follows.

1. Enter the patient information, select the VC6-2 probe and an exam type (such as the obstetric exam used throughout this chapter) to enter the B mode.
2. Optimize imaging parameters in the B mode.
3. Apply adequate gel on the patient.
4. Acquire a high quality B-mode image.
5. Tap **3D/4D** on the touch screen to enter the inactivated 4D mode by default.

NOTE:

When using a volume probe, you can set the default inactivated 3D or 4D mode. For details, refer to Section 4.1.4 Defined-Key Settings.

The 2D imaging with a ROI and a sample line is displayed in the inactivated 4D mode, only the data in the ROI is acquired for 4D imaging.

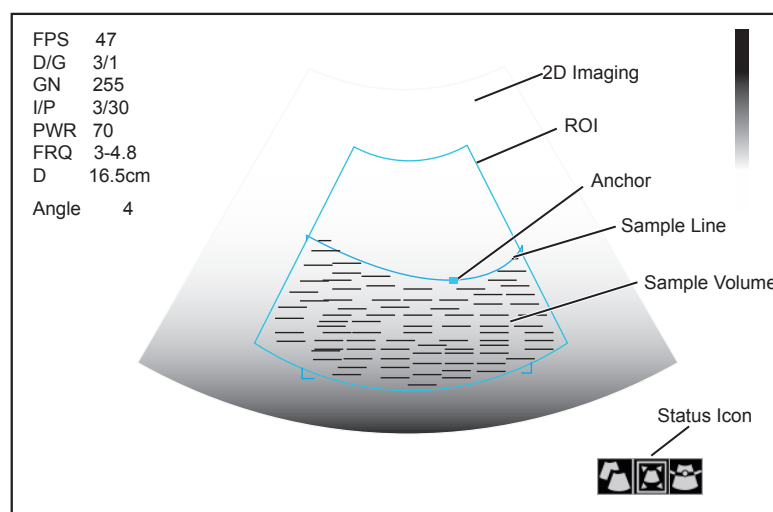





Figure 10-1 Inactivated 4D Imaging Screen

6. Adjust the ROI and sample line.

You can press the confirm key to select the desired status icon.



- If  is highlighted, use the trackball to position the ROI.
- If  is highlighted, use the trackball to resize the ROI.
- If  is highlighted, adjust the sample line by positioning the anchor with the trackball.

7. Set the stability, user mode, focus position, image quality and sweep angle.

- Tap an item under **User Mode** to select a user mode.
- Tap the Left/Right part of **Sweep Angle** to adjust the sweep angle of probe.
- Tap the left or right part of **Focus** to decrease or increase the depth of focal zone.
- Tap the left or right part of **Image Quality** to adjust quality of images.
- Select the left or right part of **Stability** to enable or disable the image quality feature.

For other parameters, refer to Section 9.2 Working with 3D Images.

8. Display the 3D imaging in the following instructions.

- Tap ,  or , tap **Start** or press the **Freeze** key to display the 4D imaging in a full, dual or quad display. The system automatically enters the 4D imaging in a quad display by default.
- Tap **1**, **2** or **4** on the key panel of the touch screen to display the 4D imaging in a full, dual or quad display.

The imaging area of the screen is divided into 3 reference images and a dynamic 3D image by default.

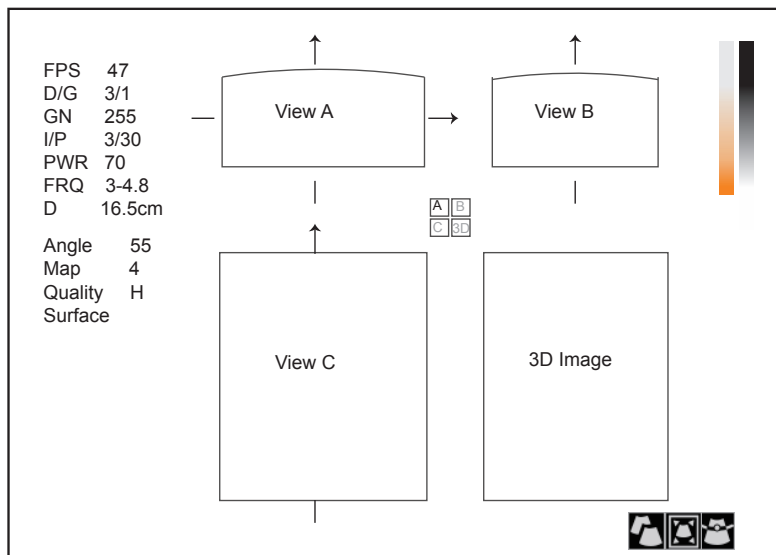

Figure 10-2 4D Imaging Screen

As the above figure shows,

- View A on the top left shows the image on the X-axis.
- View B on the top right shows the image on the Y-axis.
- View C on the bottom left shows the image on the Z-axis.
- The image on the bottom right shows the dynamic 3D image.

As Figure 10-3 shows, the touch screen displays all controls related to the 3D imaging.

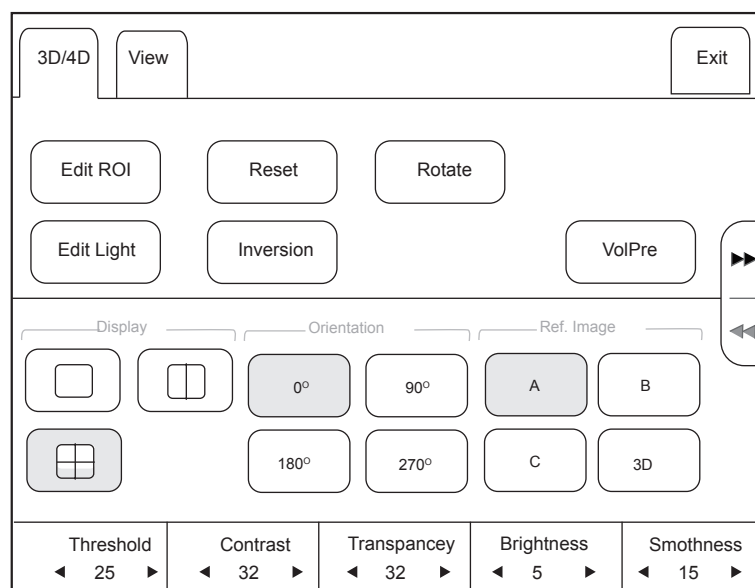

Figure 10-3 4D Imaging Parameters Menu

- Tap ►► or ◀◀ turn the current menu to the previous or the next page.
- Tap VolPre or press the Freeze key to return to the inactivated 4D mode.
- Tap Exit on the 3D/4D tab to return to the real-time B mode. Tap **Exit** on other tabs to switch to the **3D/4D** tab.

10.1.2 Acquiring Dynamic 3D Image

You can acquire a dynamic 3D image of high quality by applying the features described in Section 9.2 Working with 3D Images. You can also tap **Edit ROI** on the touch screen to freeze three reference images, and then use the trackball to view the 3D image for better observation; tap **Edit ROI** again to unfreeze three reference images.

Press the **Freeze** key on the control panel to display the progress bar of cine review. Tap **Auto Play** to play the cine review. Tap it again to stop the cine review.

10.2 Working with 4D Images

You can review, optimize or save 4D images in the frozen mode. For details, refer to Section 9.2 Working with 3D Images.

This page is intentionally left blank.

11 Working with Images

You can work with the acquired images by using the features provided by the system, such as the split screen display, panoramic display and annotations.

11.1 Imaging Features

11.1.1 Imaging Reverse

Tap  on the touch screen to reverse the real time scan left or right.

Tap  on the touch screen to reverse the real time scan up or down.

11.1.2 Split Screen Display

You can position two or four images side by side on the screen to compare the images by using the split screen display.

■ Dual-Split Screen Display

1. Press the **B**, **CFM**, **M**, **PW** or **CW** key on the control panel to select an imaging mode for a real time scan.
2. Press the **Dual** key on the control panel or tap  on the touch screen to enter the dual split Screen display.

The image is duplicated into two parts with a frozen image on the left and a real time scan on the right. The real time scan in B-mode is taken as an example in the following figure.

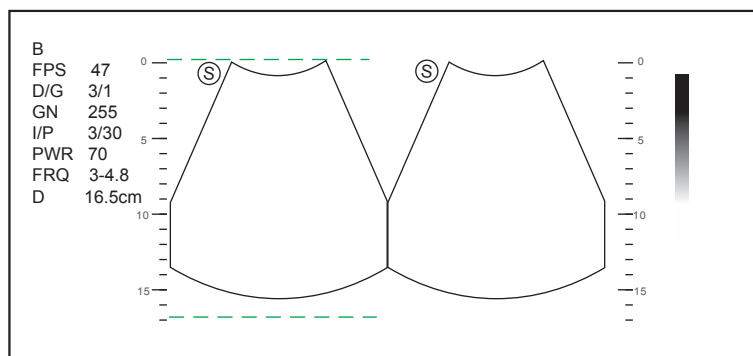



Figure 11-1 Real Time B+Frozen B

- Press the **Dual** key or tap  to freeze the real time scan and unfreeze the other image.
- Press the **CFM**, **M**, **PW** or **CW** key to select an imaging mode for the real time scan.
- Tap **Dual Live** to display two real time scans if one of the two images is a color-mode image.

The image is duplicated into two parts with two real time scans.

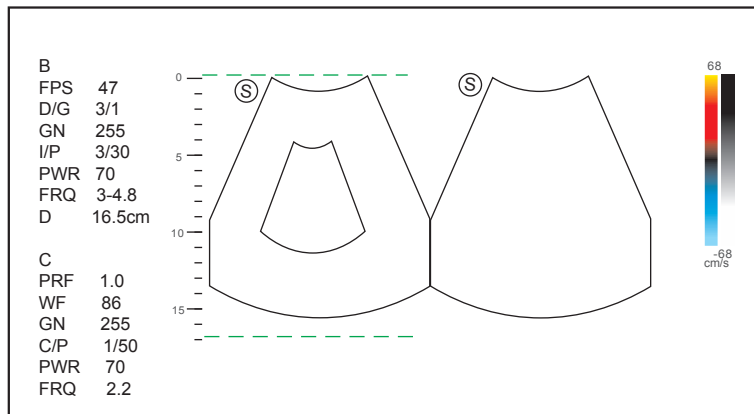



Figure 11-2 Real Time CFM + Real Time B

■ **Quad-Split Screen Display**

1. Press the **B**, **CFM**, **M**, **PW** or **CW** key on the control panel to select an imaging mode for a real time scan.
2. Tap  on the touch screen to enter the quad split screen display.
The B-mode image is taken as an example in the following figure.

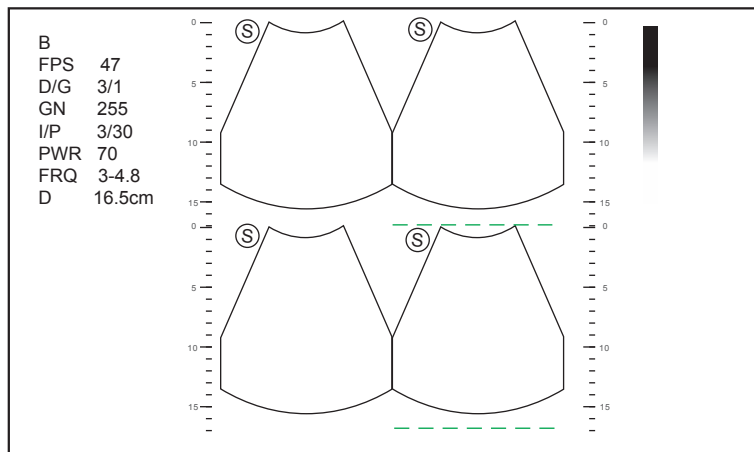



Figure 11-3 Quad-Split Screen Display

- Tap  to freeze the current image and unfreeze the following clockwise image.
- Press the **CFM**, **M**, **PW** or **CW** key to select an imaging mode for the real time scan.
- Press the **B** key to exit the quad split screen display.

11.1.3 m-Tuning

m-Tuning optimizes the image quality.

To enable m-Tuning:

Press the **m-Tuning** key on the control panel to optimize image quality.

11.1.4 Harmonic Imaging

Tissue Harmonic Imaging (THI) uses the harmonic frequencies generated by tissue. The fundamental transmit frequency results in a harmonic frequency echo. The harmonic frequency received from the tissue is a multiple of the fundamental transmit frequency. The fundamental and any accompanying artifacts are missing from the harmonic frequency that the system receives. The artifact reduction, and the concomitant reduction in haze and clutter, increases contrast resolution and improves border delineation. THI is useful in difficult-to-image patients.

In real time scan of B mode, tap **THI** on the touch screen to enable the THI mode, and **THI** or **PHI** appears at the lower left corner of the screen. Optimize the image the same way you did in the B mode.

Tap **THI** again to exit the imaging, and **THI** disappears from the screen.

NOTE

- The system automatically optimizes certain parameters (B-mode gain, frequency and frame rate) upon enabling THI.
- Compared to the B-mode imaging, THI improves image resolution but decreases the frame rate. Therefore, you should make an optimal balance when choosing an imaging mode.
- THI is only available with compatible probes.

11.1.5 Panoramic Imaging

Panoramic imaging is an imaging process that produces a panoramic image by using certain probes. The panoramic image provides sequentially and individually aligned 2D images on a static image. The 2D images are real-time, showing their anatomical context of an adjacent structure. Panoramic imaging allows you to display, view and measure a new stitched image constantly.

NOTE:

- Panoramic imaging is only available performed with linear or curved probes.
- Apply an adequate amount of coupling gel along the intended path of the scan.
- Do not shake, rotate or tilt the probe during the scan.
- Ensure the probe remains to be in contact with the skin perpendicularly during the scan.
- Do not change the scan direction or move the probe backwards and forwards.
- When the scan depth increases, generally it is generally required to decrease the scan speed.

■ Real-Time Panoramic Imaging

Perform the following steps to apply panoramic imaging.

1. Optimize the B-mode image.
2. Tap **Panoramic+** on the touch screen to enter the inactivated Panoramic Imaging mode.
You can press the **Freeze** key on the control panel to exit and return to the B mode.
3. Press the **Update** key on the control panel to enter the real-time panoramic imaging.
4. Perform the scan.

A real-time stitched image is generated, on which a probe speed box and a hint are displayed. A blue speed box indicates a slower scanning speed, a green speed box indicates a normal scanning speed and a red speed box indicates a faster scanning speed.

5. Press the **Freeze** key to display the panorama.

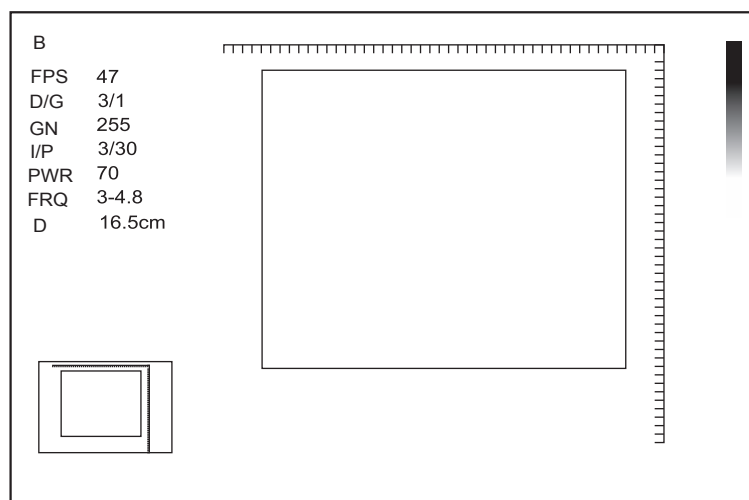

Figure 11-4 Real-Time Panoramic Imaging Screen

You can press the Freeze key again to return to the inactivated mode.

6. Work with the image.

- Magnify the Image

Tap **ZOOM** on the touch screen to enable the Picture-In-Picture feature, and a thumbnail is displayed in the lower left corner of the screen.

Use the trackball to position the interest area, and tap the left or right part of **ZOOM** to zoom in or out the image.

- Tap **Rotate** on the touch screen to rotate the image.
- Tap **Overview** on the touch screen to restore the image to the default setting.
- Make measurements, annotations and body marks.

7. Tap **Exit** on the touch screen to exit panoramic imaging.

■ **Frozen Panoramic Imaging**

NOTE:

Ensure you disable the compound imaging feature before you apply the frozen panoramic image.

1. Optimize the B-mode image, and press the **Freeze** key on the control panel to freeze the image.
2. Tap **Panoramic+** on the touch screen, and the initialization message appears on the screen.

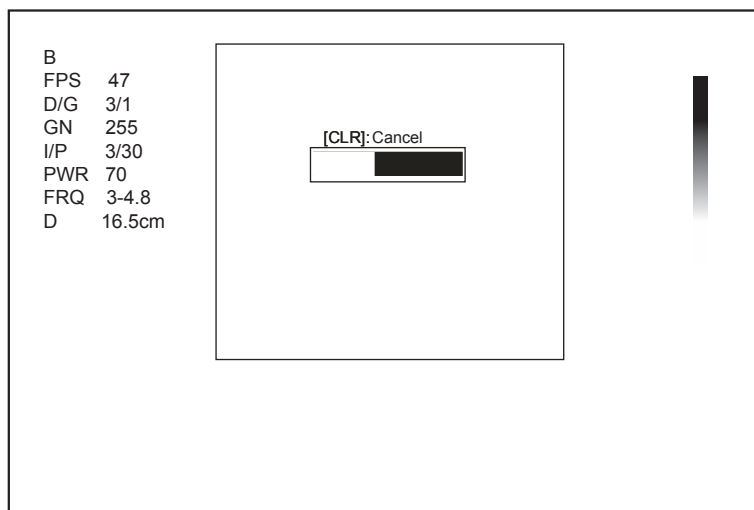

Figure 11-5 Frozen Panoramic Imaging Screen

Pressing the **Clear** key on the control panel can abort the initialization.

3. Work with the image.

- Magnify the Image

Tap **ZOOM** on the touch screen to enable the Picture-In-Picture feature, and a thumbnail is displayed in the lower left corner of the screen.

Use the trackball to position the interest area, and tap the left or right part of **ZOOM** to zoom in or out the image.

- Tap **Rotate** on the touch screen to rotate the image.
- Tap **Overview** on the touch screen to restore the image to the default setting.
- Make measurements, annotations and body marks.

4. Press the **Freeze** key twice or tap **Exit** on the touch screen to exit panoramic imaging.

11.2 Magnifying an Image

You can magnify an interest region on the imaging area.

NOTE:

The image can also be magnified in the frozen mode.

To magnify an image:

1. Press the **Zoom** key on the control panel to enable this feature.
A size multiplier is displayed in the information area of the basic screen, a thumbnail is displayed in the lower left corner of the basic screen, and the magnified image is displayed on the imaging area of the basic screen.
2. Position the ROI by using the trackball.
3. Rotate the **Depth** knob on the control panel to magnify the image in certain times.

11.3 Freezing an Image

Press the **Freeze** key on the control panel to capture an image in a real time scan or dual/quad split screen display and the feature to be applied is also activated. For this setting, refer to Section 4.1.1 General Settings.

You can select any desired image mode, magnify the image, perform measurements, add annotations and body marks and adjust imaging parameters in the frozen mode.

11.4 Using Cine

The cine review is available by pressing the **Freeze** key on the control panel and the  icon appears on the screen.

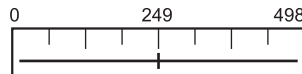

You can play back the cine by tapping **Auto Play** on the touch screen or review the cine by using the trackball. Moreover, the cine can also be cut for your actual use.

11.4.1 Reviewing Cine

- **To View Cine Manually**

You can review the cine frame by frame by using the trackball or tapping **F By F** on the touch screen in the frozen B mode. Each image is identified by a number which indicates its position in the cine.

NOTE:

- You can adjust the parameter settings when review cine.
- You can tap **To First** or **To Last** on the touch screen to review the first or last frame.

- **To Review Cine Automatically**

In the frozen mode, tap **Auto Play** to play the cine review automatically. Tap **Auto Play** again to stop the cine review.

Or, tap the left or right part of **Cine Speed** to adjust the review speed during the cine review.

11.4.2 Cutting Cine

To cut the cine:

1. Use the trackball to move the cursor to the start frame, and then press the **Update** key on the control panel.
2. Move the cursor to the end frame, and then press the **Update** key.
3. Press the **Save** () key on the control panel to save the cut cine.

11.5 Annotations and Body Marks

The annotation feature allows you to type or add an annotation from the predefined annotation library. You can annotate the cine, real-time image or frozen image. Arrows and body marks are also provided to annotate the image.

NOTE:

You should define an annotation library before applying this feature. For details, refer to Section 4.3 Defining Annotation Library.

11.5.1 Annotating an Image

■ Annotating an image with Typed Words

Perform the following steps:

1. Press the **Annot** key on the control panel.
The cursor becomes | on the screen and the predefined words appears on the touch screen.
2. Move the cursor to the desired place by using the trackball and tap the predefined word on the touch screen to add it to the image.
 - Move the cursor to the desired place and input an annotation manually by using the key panel.
 - Move the cursor to an annotation and press the confirm key. Then move the annotation to the desired position by using the trackball and press the confirm key.
 - Move the cursor onto an annotation to edit it by using the key panel.
3. Repeat the above steps to add more annotations if necessary.
4. Press the **Annot** key again or tap **Exit** on the touch screen to exit.

■ Annotating an Image with Arrows

Perform the following steps:

1. Press the **Arrow** key on the control panel, and the cursor becomes an arrow.
2. Position the arrow to the desired place by using the trackball, and press the confirm key to add it on the image.
If necessary, rotate the **Angle** knob to adjust the arrow angle.
3. Repeat the above steps to add more arrows if needed.

■ Setting an Initial Position for an Annotation

Perform the following steps.

1. Press the **Annot** key on the control panel and the cursor becomes | on the screen.
2. Move the cursor to the desired position by using the trackball and tap **Set Home** to set the initial position for an annotation.

After the settings,

- if a text annotation is being edited, tap **Home** to move the cursor to the initial position.
- if a text annotation is being moved, tap **Home** to move the text annotation to the initial position.
- when entering the text or arrow annotation screen next time, the cursor appears in the initial position set this time.

11.5.2 Body Mark

Perform the following steps.

1. Press the **Body Mark** key on the control panel.
The first body mark of the desired exam type is added to the image by default.

2. Tap a body mark on the touch screen to add it to the image.
3. Position the probe marker to the desired place by using the trackball.
If necessary, rotate the **Angle** knob on the control panel to adjust the angle.
4. Press the confirm key to add it to the image.

11.5.3 Deleting Annotations and Body Marks

■ To Delete Annotations

Perform the following steps.

1. Press the **Annot** key on the control panel to enter the text annotation screen.
2. Move the cursor onto the annotation and then tap **Delete** on the touch screen.

NOTE:

You can enable the annotation-cleared feature. For details, refer to Section 4.1.1 General Settings.

■ To Delete Body Marks

Perform the following steps.

1. Press the Body Mark key to enter the body mark editing mode.
2. Tap Delete on the touch screen.

■ To Delete All Annotations and Body Marks

You can press the **Clear** key on the control panel to delete all annotations and body marks from the image. You can also tap **Clear** on the touch screen to delete them from the image when they are being edited. Perform this deletion with caution.

11.6 Using ECG

Using an optional ECG module (Type BF), 3-channel ECG signals are provided in cardiac applications. During an cardiac application, you can configure the ECG-control so that the ECG trace is displayed at the bottom of the screen.

The ECG cable includes three color-coded ECG electrode connectors, i.e., LL (left leg, red), LA (left arm, black) and RA (right arm, white).

The ECG module provided by this ultrasound system is for collecting and displaying 3-lead ECG trace.



- This ECG module is not suitable for intracardiac use or direct cardiac contact.
- This ECG module provides 3-channel ECG signals and cannot be used for diagnosis and monitoring.
- To avoid electrical shock, ensure the ECG cable is intact and be correctly connected.
- Conductive parts of electrodes and connectors for ECG should not come into contact with other conductive parts including earth/grounding.
- Power off the system if the patient is found to use a pacemaker or implantable cardioverter-defibrillators, because the system may interfere with these devices.

11.6.1 Basic Procedures of ECG Operation

Perform the following steps:

1. Power off the system and connect the ECG cable to the specific port of the system.
2. Power on the system and attach the ECG electrodes on the patient's body (as shown in the following figure).

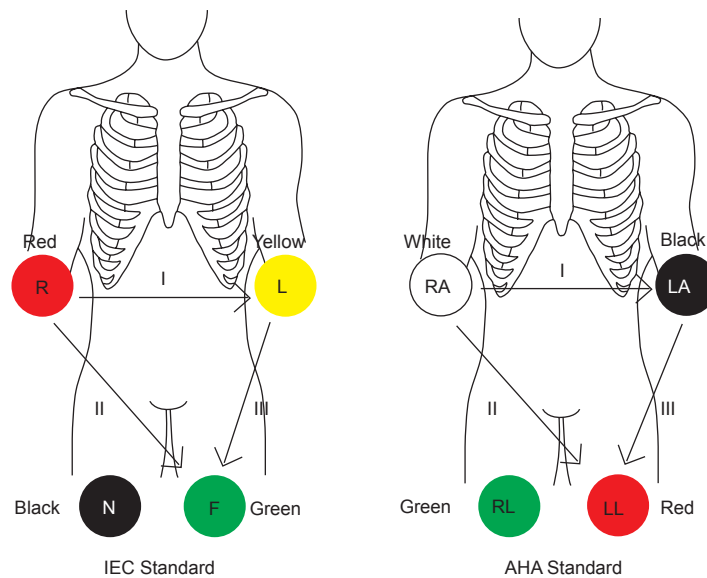

Figure 11-6 Electrode Placement

3. Make the relevant settings of the ECG module. For details, refer to Section 11.6.2 Optimizing Parameters.
4. Freeze the images and review them. For details, refer to Section 11.6.3 Reviewing ECG.
5. Exit the ECG mode, and remove ECG electrodes from the patient.

11.6.2 Optimizing Parameters

Tap **ECG** on the touch screen to display the submenu of the ECG module. Or, tap **ECG** again to hide it.

Item	Description
ECG ON/OFF	Display or hide the ECG waveform.
ECG Gain	Set the amplitude of the ECG waveform.
ECG Position	Set the vertical position of the ECG waveform.
ECG Invert	Enable or disable the waveform inversion function.
R-Trigger	<p>Enable or disable the R-trigger function.</p> <p>When enabled, the R-Trigger menu pops up, the menu contains Trigger Delay, Frame Count, and Frame Int.</p> <p>NOTE: In order to enable the R-trigger function, you should disable the compounding imaging function first.</p>
Trigger Delay	Delay of trigger after the 2D refresh.
Frame Count	Image frames transferred per second.
Frame Int.	Interval between 2D image refresh.

11.6.3 Reviewing ECG

Press the **Freeze** key on the control panel to freeze an image and the ECG waveform is frozen at the same time. The ECG waveform is the reference for time.

12 Managing Images/Data

Images in this ultrasound system include frame images and cine, you can save or review them after the acquisition. Meanwhile, images can be also backed up to a USB drive or a DVD for future review if it is needed.

12.1 Storing an Image

NOTE:

- Keys can be defined on the General Settings menu - Key Configuration tab. For details, refer to 4.1.4 Defined-Key Settings.
- All data is saved to the system by default. If a USB drive is connected and **Store to UsbDisk** is ticked on the General Settings menu - Key Configuration tab, the saved data will be synchronously stored to the USB drive.

12.1.1 Storing 2D Image

Press the **Save** (📁) key on the control panel in the real time or frozen mode to save the current image. Press the **Save** (📁) key on the control panel in the frozen mode to save the current cine.

The system beeps if the image is saved successfully. Meanwhile, the corresponding thumbnails for the stored image or cine also appears in the clipboard.

12.1.2 Storing 3D/4D Image

1. Press the **Save** (📁) key on the control panel in the 3D/4D mode.
2. Select **Image** in the pop-up dialogue box to save the current image.
Or, select **Volume** in the pop-up dialogue box to save the volume data.

In the 4D mode, you can also select **Cine** in the pop-up dialogue box to save the current cine.

The system beeps if the image is saved successfully. Meanwhile, the corresponding thumbnails for the stored image, cine or volume data also appears in the clipboard.

12.2 Viewing an Image

You can view the images for the current or a previously examined patient by using the clipboard or the **Review** screen.

12.2.1 Viewing a Current Image

■ To View an Image by Using the Clipboard

1. Press the **Pointer** key on the control panel in the real time or the frozen mode.
2. Select the image in the clipboard by using the trackball, and then press the confirm key to view the image/cine.
 - Click (📁) to select all images.
 - Click ◀ or ▶ to go to the previous or the next page.
 - Click (📁) to export images to the USB drive or DICOM.
 - Click (🗑️) to delete the desired image/cine.
 - You can also amplify the image or review the cine and perform a measurement.

■ **To View an Image on the View Image Screen**

1. Press the **Review** key on the control panel to enter the **View Image** screen.
The following screen is displayed with images and cine thumbnails.

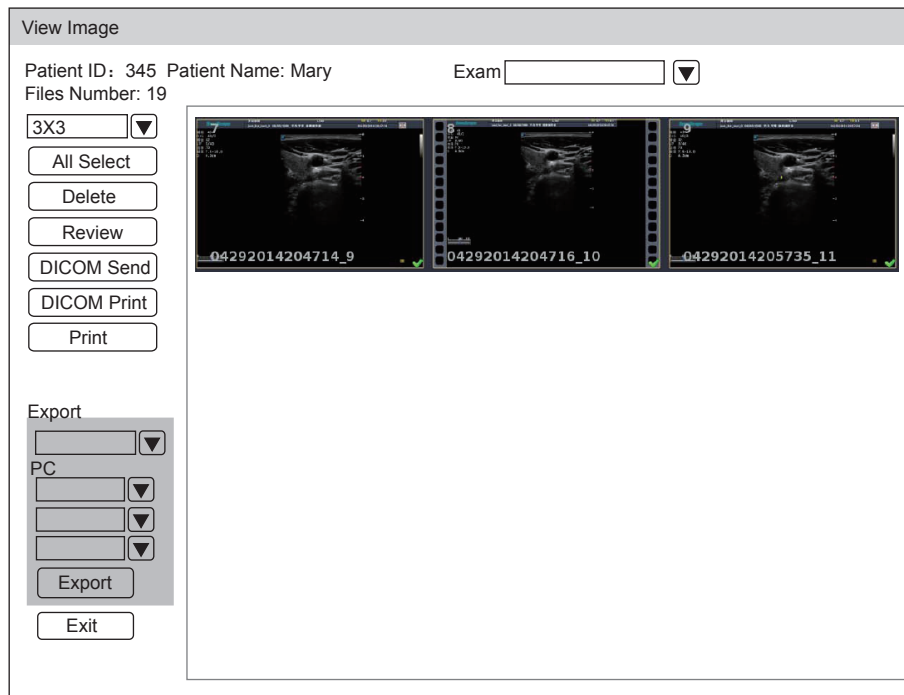

- If the patient has had more than one exam, you can select the desired exam from the **Exam** drop-down list.
2. Move the trackball to the thumbnails and select the confirm key to choose one image.
 3. View the image.
 - Double-click the confirm key to view an image.
You can press the **Freeze** key at any time to return to the **View Image** screen.
 - Click **Review** to view the image.

12.2.2 Retrieving an Image

Perform the following steps.

1. Choose the **Patient** key > **Patient List** > **Patient Review** to enter the **Patient Review** screen.
2. Select the desired patient, and then click **View** to enter the **Exam Review** screen.
3. Select the desired exam, and click **View Image** to retrieve the image.

12.3 Sharing Data

You can remote access to the data stored in the system through a computer.

Perform the following steps.

1. Connect the computer to the system.
2. Set **Image Share Service** to **On** on the General Settings menu - Storage tab.
3. Type the IP address in the search box of the computer and press **Enter**.
4. Type the user name and password in the pop-up dialogue box.

12.4 Backing up Data



- All data is saved to the system by default. To avoid data loss due to unexpected system breakdown or software update, you are highly recommended to back up data backup.
- Complete all exams before backing up the data.

12.4.1 Backing up Data to a USB drive

Perform the following steps.

1. Connect a USB drive to the system.
2. Choose the **Patient** key > **Patient List** > **Patient Review** to enter the **Patient Review** screen.
3. Select **USB** from the **Import/Export** drop-down list.
4. Click **Export Screen** and then select the exported image format.
If you select PC image format, you can also select the exported image or cine format.
5. Select the desired patient.
6. Click **Patient Export** to back up all data relevant to the patient.

If only images are needed to be exported, you can export them on the **View Image** screen.

12.4.2 Backing up Data to DVD

You can use a DVD with the system. DVD (DVD-R/RW, DVD+R/RW, not less than 4.7GB capacity or more) manufactured by SONY is recommended.

Perform the following steps.

1. Place an empty DVD in the CD-ROM drive.
NOTE:
Please make sure the DVD is facing upward in the CD-ROM drive.
2. Choose the **Patient** key > **Patient List** > **Patient Review** to enter the **Patient Review** screen.
3. Select **DVD** from the **Import/Export** drop-down list.
4. Click **Export Screen**, and then select the exported path.
5. Select the desired patient.
6. Click **Patient Export** to back up all data relevant to the patient.
DVD ejects after a successful data backup export prompt is displayed.
7. Take out the DVD from the CD-ROM drive and close the tray.

If only images are needed to be exported, you can export them on the **View Image** screen.

12.5 Importing Data to the System

NOTE:

- Only data generated by this ultrasound system can be imported.
- Ensure the current exam is completed before you import data. Otherwise, you may have a failure data import.

Perform the following steps.

1. Connect the USB drive to the system.
Or, place an empty DVD in the CD-ROM drive.
2. Choose the **Patient** key > **Patient List** > **Patient Review** to enter the **Patient Review** screen.

3. Select the imported device from the **Import/Export** drop-down list.
4. Click **Export Screen** and then select the imported patient information.
5. Click **Patient Import** to import the desired data.

13 Working with DICOM

DICOM (Digital Imaging and Communications in Medicine) is a standard created by National Electrical Manufacturers Association (ACR-NEMA) to regulate the distribution and viewing of medical images such as ultrasound images and cine.

If the system is configured with the DICOM module, you can:

- Search the archived patient information set on the DICOM server, and copy the patient information to the system so that the correct patient can be examined.
- Send stored images or data on the system to the DICOM server.
- Print images on a DICOM printer.

DICOM service of the system consists of DICOM storage, DICOM print, DICOM worklist, MPPS and storage commitment.

If you need *DICOM 3.0 Compatibility Declaration*, please contact the manufacturer.

13.1 Verifying Connectivity

Perform the following steps.

1. Connect the system to the local DICOM network server by using a network cable.
2. Edit the relative settings for the local network and DICOM server. For details, refer to Section 4.2 Peripheral Device Settings and 4.8 Configuring DICOM.
3. If the verification is successful, you can use the DICOM services.



NOTE:

Ensure the system is connected to the server before using the DICOM service. Otherwise, the service cannot be used.

13.2 DICOM Storage

DICOM Storage is used to send patient data to the DICOM storage server for storage.

13.2.1 Storing the Current Image

1. Connect a USB drive to the system.
2. Define the **Save** () key or the **P1** key as **Dicom Send** on the General Settings menu - Key Configuration tab.
3. Press the **Save** () key or the **P1** key in the real-time or frozen mode to send the current image to the DICOM storage server.

If the transmission fails, a prompt displays on the bottom right of the screen.

13.2.2 Storing Patient Data

1. Choose the **Patient** key > **Patient List** > **Patient Review** to enter the **Patient Review** screen.
2. Select the desired patient, and then click **View** to enter the **Exam Review** screen.

3. Select the desired exam.
4. Click **DICOM Send** to send the patient information and the relevant images to DICOM storage server.

If you only want to send images, press the **Review** key on the control panel to enter the **View Image** screen, select the desired images, and then click **DICOM Send**.



If you want to check the status of items sent to the DICOM storage server, choose the **Patient** key > **Patient List** > **DICOM Queue**.

13.3 DICOM Print

DICOM Print is used to send images to the DICOM print server for printing.

You should properly connect the system to the print server and edit the relevant settings. For details, refer to 4.8.5 Print Service Settings.

13.3.1 Print the Current Image

1. Define the **Save** () key or the **P1** key as **DICOM Print** on the General Settings menu - Key Configuration tab.
2. Press the **Save** () key or the **P1** key in the real-time or frozen mode to send the current image to the DICOM printer server.

13.3.2 Print Patient Data

1. Choose the **Patient** key > **Patient List** > **Patient Review** to enter the **Patient Review** screen.
2. Select the desired patient, and then click **View** to enter the **Exam Review** screen.
3. Select the desired exam.
4. Click **DICOM Print** to send the patient information and the relevant images to DICOM print server.

If you only want to send images, press the **Review** key on the control panel to enter the **View Image** screen, select the desired images and then click **DICOM Send**.

If you want to check the status of items sent to the DIOCM print server, choose the **Patient** key > **Patient List** > **DICOM Queue**.

13.4 DICOM Worklist

The DICOM Worklist is used to search the archived patient information on the DICOM server, and copy the patient information to the system so that the correct patient can be examined.

Press the **Patient** key on the control panel to enter the **New Patient** screen and then click **WorkList** to enter the **WorkList** screen.

The screenshot shows a software interface titled "WorkList". At the top, there are search filters: "Patient Name" and "Patient ID" with input boxes and a "Search" button; "Accession#" and "Requested Procedure ID" with input boxes and a "Reset" button; and a "Date" range from "05/04/2016" to "05/05/2016" with dropdown arrows, and an "Only US" checkbox with a dropdown arrow. Below the filters is a section titled "Worklist Information" containing a table with the following headers: Patient ID, Patient Name, Birth Date, Sex, Description, Requested Procedure ID, Accession#, and Date/Time. The table body is currently empty. At the bottom right of the interface are three buttons: "Group Case", "Select", and "Cancel".

Figure 13-1 WorkList Screen

Perform the following steps.

1. Search for the patient information

Enter the search requirements, such as Patient Name, Patient ID, Accession#, Exam Date/Time or Requested Procedure ID, and then click **Search** to search for the desired information.

Clicking **Reset** can clear all the search information.

Clicking **Date/Time** can display the patient data by order of oldest or newest input date/time.

2. Start an exam

- a. Select the desired patient.

- b. Click **Select** to start an exam. If the desired patient has taken more than one exam, click **Group Case** to start the exam.

3. Enter patient information.

13.5 MPSS

MPSS is used to send exam status information to the MPSS server, which facilitates the other systems to obtain the exam progress in time.

The status information is described as below:

- When the exam is started, the system sends the status information "In Process" to the MPSS server.
- When the exam is completed by pressing the **End Exam** key on the control panel, the system sends the status information "Complete" or "Discontinue" to the MPSS server.

If you want to check the status of items sent to the MPSS server, choose the **Patient** key > **Patient List** > **DICOM Queue**.

You can manually add MPSS to check the processing status of the discontinued exam or other order operations.

NOTE:

MPSS can only be added when you perform the scan or other order operations.

Perform the following steps.

1. Choose the **Patient** key > **Patient List** > **Patient Review** to enter the **Patient Review** screen.
2. Click **PPS Screen** to enter the **PPS** screen.

The screenshot shows a window titled "PPS Screen". It contains two main sections:

Information

Patient ID	Patient Name	Birth Date	Sex	Description	Date/Time	State
20140505	Mary		Unknown			IN PROGRESS

Scheduled Procedure Step Information

Code	Description	Meaning

At the bottom right of the window are two buttons: "Append" and "Exit".

Figure 13-2 PPS Screen

The **PPS** screen displays MPPS information about the current patient. If the patient information is acquired from the DICOM WorkList, the **PPS** screen will also display the relevant acquisition protocol.

3. Click **Append** to display the following dialogue box.

The screenshot shows a dialogue box titled "PPS". It contains the following fields and controls:

- Assisted Acquisition Protocol Setting
- Code:
- Meaning:
- Designator:
- Reason: (with a dropdown arrow)
- Buttons: "Completed" and "Discontinued"

4. Click **Assisted Acquisition Protocol Setting**, and then enter the relevant information to code, meaning and designator.
 5. Click **Completed** to end the order operation.
- Or, you can also click **Discontinued** if needed.

13.6 Storage Commitment

Storage commitment is used to confirm whether the images or structured reports are successfully stored to the DICOM storage server.

If you want to check the status of items sent to the DICOM storage server, choose the **Patient** key > **Patient List** > **DICOM Queue**.

13.7 DICOM Queue

The DICOM Log is used to check the sending status of DICOM storage, DICOM print, MPPS and Storage Commitment.

Choose the **Patient** key > **Patient List** > **DICOM Queue** to enter the DICOM Queue screen.

DICOM Queue Information									
	Type	Patient ID	Patient Name	Server	Start Time	Size	Run State	Status	Details
<input type="checkbox"/>	MPPS	20140505	Mary	AE	12/05/2016-16:04:03	0M	Finish	Fail	Association Request Failed

Figure 13-3 DICOM Queue Screen

Perform the following steps.

1. Search for the patient information

Enter the search requirements, such as Patient Name, Patient ID, Type or Exam Date/Time, and then click **Search** to search for the desired information.
2. Check the sending status

You can check the sending status by viewing **Run State**, **Status** or **Details**.
3. Deal with the failure sending information
 - Select the desired patient information and click **Refresh** to refresh the patient information. If it does not work, you can click **Resend** to resend the information.
 - Click **All Select** > **Resend Fail** to resend all information.
 - Select the desired patient information and click **Delete** to delete the information.

13.8 Query/Retrieve List

The **Query/Retrieve List** is used to retrieve patient information from the query server. User can import the retrieved patient exam information to the system and view it.

Press the **Patient** key on the control panel to enter **New Patient** list. Click **Patient List** to enter **Patient List** screen and click **DICOM Q/R** to enter **Query/Retrieve List** screen.

Figure 13-4 Query/Retrieve List

Perform the following steps.

1. Retrieve patient information.

Select the desired query condition, such as **Patient ID**, and enter the related information. Click **Search**, and patient information will be displayed on the **Query/Retrieve** list.

Click **Reset** to delete the entered query condition.

Click **Date/Time**, the system will arrange the patient information in chronological order of exams.

2. Import patient information.

Select the desired patient information on the **Query/Retrieve List** and click **Retrieve** to import the patient information to the system. If the information is imported successfully, user can view the patient information on the **Patient List** screen.

14 Probes and Biopsy

You should become thoroughly familiar with the operations of the probe and biopsy bracket before using them. To ensure the performance of the probe and the biopsy bracket, you should periodically check, clean, disinfect and maintain them.

NOTE:

A general instruction for the probe and the biopsy bracket is provided in this manual. For details, refer to the relevant manuals.

14.1 Probe

This ultrasound system supports a wide range of probes which make the system remarkably versatile.

The schematic diagrams of probes are as follows.

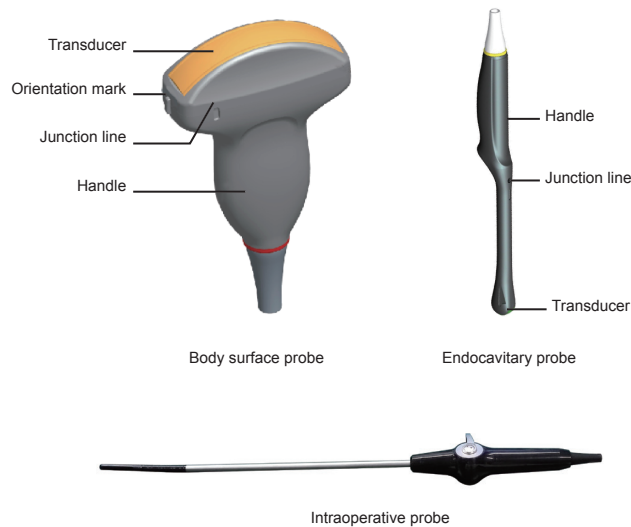

14.1.1 Available Probes

The available probes are listed as follows.

Probe Model	Application
C322, C344, C353, C354, C542, C611, C613, L741, L742, L752, 2P1, 5P1, 10L1, VC6-2, CWD2.0, CWD5.0, PWD2.0, 3C-A, 4P-A, 3P-A, 7P-B, 18L-A, 6CT-A, 12LT-A, 6CI-A, 12LI-A, 9L-A, 13L-A, 3C-B, 4P-B, 12P-B	Body surface
6V1, 6V3, 6V7, 6V1A, 6V2A, EC9-5, BCL10-5, BCC9-5, MPTEE, MPTEE mini, 12C-ER, 6V-A, 8V-A	Intracavitary
10I2, 10L-I, LAP7	Intraoperative

14.1.2 Probe Usage



- Use only the probes provided by the manufacturer. Otherwise, the system may not perform and an accident such as a fire may result.
- Use the probe carefully. If any part of the probe surface is scratched, immediately stop using the probe. Otherwise, electrical shock may occur.
- A legally marketed probe sheath is required for intracavitary operations. If lubricant is used, it must be water-soluble. Do not apply coupling gel directly on the patient's skin. Please dispose of the sheath in accordance with local laws and regulations.
- Use a sterile probe sheath and sterile coupling gel when performing an intraoperative, trans-vaginal, trans-rectal or trans-esophageal (Cardiac) exam. If lubrication is insufficient because of age and personal reason during the exam, you need to apply a sufficient amount of sterile coupling gel on the surface of the sheath.
- To avoid contamination, please use the coupling gel and probe sheath before performing an exam.
- Use legally marketed coupling gel in accordance with the relevant local regulations. Read and understand all precautions in the relevant manual of the coupling gel before use. For recommended coupling gels, please refer to Appendix D.1 Coupling Gel.
- Latex or natural rubber contained inside medical equipments or accessories can cause severe anaphylactic reactions in some individuals. It's suggested by the FDA that the operator should identify latex-sensitive patients and be prepared to treat anaphylactic reactions promptly.
- After being contaminated by pathogenic bacterium that is hard to kill, such as cryptosporidium or prion virus, the probe and its accessories should be destroyed by melting or burning when necessary because they cannot be completely disinfected or sterilized.



- Avoid immersing the transducer surface in the coupling gel for a long period of time. Otherwise, damage to the probe may occur.
- Avoid any fluid flowing into the probe or probe connector when cleaning, disinfecting or sterilizing the probe and probe cable.

■ Special Concerns before Probe Usage

Inspect the probe before each use. If the following damage is found, stop using the probe immediately.

- Cracks on the probe handle (user section).
- Cracks on the transducer surface (applied section).
- Scratches on the transducer surface (acoustic window surface).
- Swell of the acoustic window material.
- Cracks or wear on the probe cable.
- Cracks on the probe connector or any other kinds of visible damage.
- Deformed pins or broken pins exist inside the probe connectors.

■ Body Surface Probe Usages

1. Wear medical sterile gloves.
2. Orient the probe.
3. Perform a scan.

■ Endocavitary Probe Usages

1. Wear medical sterile gloves.
2. Wear the probe sheaths
 - a. Remove the packaging and unfold the probe sheath.

- b. Apply an appropriate amount of coupling gel to the inside of the sheath and onto the face of the probe.



- c. Hold the probe and unroll the sheath onto the probe.
 - d. Pull the probe sheath tightly over the face of the probe to remove wrinkles.
 - e. Secure the sheath to the probe with the adhesive tapes or elastic bands.
3. Orient the probe
 - Check the probe orientation mark before the scan.
 4. Perform a scan.

■ Intraoperative Probe Usages

1. Wear medical sterile gloves.
2. Ensure the bending section of intraoperative probe is release and can be bent freely.
 - a. Rotate two angulation knobs to adjust the probe distal end to the desired angle.
 - b. Lock the angulation knobs if they are adjusted properly.

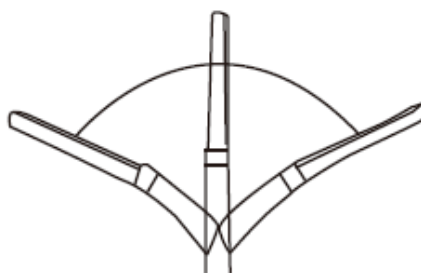

3. Perform a scan.

14.1.3 Cleaning the Probe



- To avoid electrical shock, disconnect the probe from the system before cleaning.
- To avoid potential disease transmission, you should wear sterile medical gloves and protective goggles while cleaning.



- Do not use cleaner that contains sodium sulfate and/or sodium hypochlorite to clean the probe. Otherwise, the probe may be damaged.
- To avoid probe damages, do not bump the probe on hard surfaces.
- Use only the cleaner recommended by the manufacturer to clean the probe. Otherwise, the probe may be damaged.

You should clean the probe before and after each use. Probe cleaning is an essential step of the disinfection and sterilization.

Perform the following steps to clean the probe.

1. Remove the coupling gel from the probe surface after exam.
2. Disconnect the probe from the system and remove the probe sheath and biopsy bracket from the probe.

3. Use a lint-free soft cloth dampened with mild soapy water or the recommended cleaner (see Appendix D.2 Cleaner) to wipe the probe.
If there are dried stains on the surface or in the grooves of the probe, remove them by a brush dampened with an enzymatic clearer.
4. Rinse the surfaces of the probe with the fresh running water to completely remove any residual cleaner.
5. Dry the probe with a lint-free soft dry cloth.

14.1.4 Disinfecting and Sterilizing the Probe



- There is a cleared list of sterilants and high-level disinfectants for use in processing reusable medical and dental devices on the FDA website. That list can be consulted to find agents that may be useful for probe disinfection. Please refer to the following URL for FDA-Cleared Sterilants and High Level Disinfectants: <http://www.fda.gov/MedicalDevices/DeviceRegulationandGuidance/ReprocessingofSingle-UseDevices/ucm133514.htm>.
- Use the liquid disinfectant/sterilant that meets the local laws and regulations or the recommended disinfectant/sterilant.
- The probe sheath may be damaged during exam and contamination risk level caused by the damaged sheath is difficult to estimate. Therefore, probe sheath cannot change the level of disinfection for a probe. Please clean and sterilize (or high level disinfect) the entracavitary probe and clean and sterilize the probe for biopsy and coming into contact blood after exam.
- Do not use an expired disinfectant/sterilant.
- Store the probe in a sterile environment, and review its expiration date before use.



- If you use the recommended disinfectant/sterilant, ensure the requirements for the disinfection level and probe soaking period are met. Otherwise, the probe could be damaged and your warranty may be void. If you have further use or needs for the probe, ensure the level of the make-up disinfectant/sterilant and the probe soaking period are suitable for the intended clinical application.
- Do not use the following methods to sterilize the probe.
 - Autoclave
 - Ultraviolet sterilizer
 - Gamma ray sterilizer
 - Ethylene oxide gas
 - Ethylene oxide
 - Thermal disinfection/sterilization. Temperature higher than 66°C (150°F) will damage the probe.
- Do not allow any disinfectant/sterilant to be air-dried on the probe.

■ Disinfection Levels

To choose an appropriate disinfectant, you first must determine the required level of disinfection, based on the probe applications.

Classification	Definition	Level of Disinfection	Application
Critical	A device that enters normally sterile tissue or the vascular system.	Sterilization	Intraoperative, biopsy use or blood contacting probe
Semi-critical	A device that comes into contact with intact mucous membranes and does not ordinarily penetrate sterile tissue.	High	Endocavitary probe
Noncritical	Devices that do not ordinarily touch the patient or touch only intact skin.	Medium or low	Body surface probe

■ Immersion Requirements

Do not immerse the probe beyond its junction line.

■ To Disinfect the Body Surface Probe

You should disinfect the surface probe after each use.

Perform the following steps:

1. Clean the probe.

For details, refer to Section 14.1.3 Cleaning the Probe.

2. Perform the medium-level disinfection to the surface probe as shown in Table 14-1 until the recommended disinfection period expires.

Or select a recommended disinfectant (see Appendix D.3 Disinfectant) to disinfect the probe by following the instruction provided by disinfectant's manufacturer.

3. Rinse the probe with the fresh running water to remove the residual disinfectant completely.
4. Dry the probe with a lint-free soft dry cloth.

Table 14-1 Recommended Method for Medium-level Disinfection

Disinfectant	Manufacturer	Active Ingredients	Level for Active Ingredient	Contact Type	Contact Period
70% Isopropyl alcohol	All	Isopropyl alcohol	70%	Spray/Wipe	<10 minutes
T-spray II	Pharm. Inc.	Quat. Ammonia	/	Spray/Wipe	<10 minutes
T-spray	Pharm. Inc.	Quat. Ammonia	/	Spray/Wipe	<10 minutes

■ To Disinfect the Endocavitary Probe

You should disinfect the endocavitary probe before and after each use.

Perform the following steps:

1. Clean the probe.

For details, refer to Section 14.1.3 Cleaning the Probe.

2. Perform the high-level disinfection to the endocavitary probe as shown in Table 14-2 until the recommended soaking period expires.

Or select the recommended disinfectant (see Appendix D.3 Disinfectant) to disinfect the probe by following the instruction provided by disinfectant's manufacturer.

3. Rinse the probe with the running sterile water to remove the residual disinfectant completely.
4. Dry the probe with a lint-free soft dry cloth.

Table 14-2 Recommended Method for High-level Disinfection

Disinfectant	Manufacturer	Active Ingredients	Level for Active Ingredient	Contact Type	Contact Period
Cidex™ Activated Dialdehyde Solution	J&J	Glutaraldehyde	2.4%	Soak	45 - 50 minutes
Resert XL HLD	STERIS	H ₂ O ₂	2.0%	Soak	8 minutes

■ **To Sterilize the Probe**

You should sterilize the intraoperative, biopsy use or blood contacting probe after each use.

Perform the following steps:

1. Clean the probe.
For details, refer to Section 14.1.3 Cleaning the Probe.
2. Sterilize the probe as shown in Table 14-3 until the recommended soaking period expires.
Or select the recommended disinfectant (see Appendix D.3 Disinfectant) to sterilize the probe by following the instruction provided by disinfectant’s manufacturer.
3. Rinse the probe with the running sterile water to remove the residual sterilant completely.
4. Dry the probe with a lint-free soft dry cloth.

Table 14-3 Recommended Method for Sterilization

Sterilant	Manufacturer	Active Ingredients	Level for Active Ingredient	Contact Type	Contact Period
Cidex™ Activated Dialdehyde Solution	J&J	Glutaraldehyde	2.4%	Soak	10 hours

14.1.5 Disinfecting and Sterilizing the Probe Cable



WARNING To avoid potential disease transmission, you should wear sterile medical gloves and protective goggles during disinfection or serialization.



CAUTION Do not immerse the probe cable in alcohol or isopropyl alcohol at any concentration for a long period of time. Avoid any contact with iodine or phenols. Otherwise, it will accelerate the aging of the cable and decrease the service time of the probe, or even result in cable damages.

■ **Disinfection**

Perform the following steps to disinfect the probe cable.

1. Use a lint-free soft cloth dampened with mild soapy water to wipe the probe cable.
2. Rinse the cable with fresh running water to completely remove the residual cleaner.
3. Perform the medium-level disinfection to the probe cable as shown in Table14-4.
4. Rinse the surfaces of the probe cable with fresh running water to completely remove the residual disinfectant.
5. Dry the probe cable with a lint-free soft dry cloth.

Table 14-4 Recommended Method for Medium-level Disinfection

Disinfectant	Manufacturer	Active Ingredients	Level for Active Ingredient	Contact Type	Contact Period
T-spray II	Pharm. Inc.	Quat.Ammonia	/	Spray/Wipe	<10 minutes
T-spray	Pharm. Inc.	Quat.Ammonia	/	Spray/Wipe	<10 minutes

■ **Sterilization**

If the probe cable contacts with any blood or body fluid you should sterilize it. For details, refer to the information about probe sterilization.

14.1.6 **Storage and Transportation**

You should store or transport the probe in accordance with Appendix A Specifications.

■ **To Store the Probe**

Follow the following items to store the probe.

- Store the probe in a probe holder or specific package when not in use.
- Ensure the probe holder is clean before storing it.
- To avoid contaminating the package, disinfect or sterilize the probe before storing it or store it in a disposable probe package.
- Do not expose it to direct sunlight or sudden environmental temperature changes.
- Store the probe alone to avoid any impact on the probe head.
- Carefully wind the probe cable.
- Dry the probe before storing it.

■ **To Transport the Probe**

Perform the following steps to transport the probe.

1. Clean and disinfect the probe before transportation.
2. Place the probe fully into the carrying case and carefully wind the cable.
3. Close the cover of the carrying case.
4. Pack the carrying case with sponge and place it in a carton.

14.2 **Biopsy**



- **WARNING** Only use the biopsy bracket in conjunction with the probe provided by the manufacturer. Otherwise, the system and probe may be damaged, an accident such as a fire may result in the worst case.
- Only trained physicians or sonographers under ultrasound guidance can handle the biopsy needle guides. During operation, the operator must observe the proper needle insertion sequencing with the needle guide in order to avoid undue discomfort and unnecessary risk and injury to the patient.
- The biopsy guidelines that display on the monitor are intended as a reference. It is the operator's responsibility to verify the correct positioning of the needle during a biopsy.
- Do not use a needle guide if the path of the needle is not accurately indicated by the on-screen guidelines. The path of the needle must be displayed within the guidelines. Contact the manufacturer or the local distributor if the needle path is not accurately indicated.
- Do not freeze an image when performing a biopsy.
- To avoid hurting the patient accidentally, the operator should be highly focused during a biopsy.
- You should activate the biopsy guidelines before performing a biopsy.
- The biopsy needle is disposable.
- To avoid infection, disinfect the probe and cover it with the probe sheath when performing a biopsy.
- To avoid possible personnel injury, the operator should perform the biopsy using an appropriate biopsy bracket.

14.2.1 Available Biopsy Brackets

Biopsy Bracket Model	Available Probe Model	Available Biopsy Needle	Application
NGBC322	C322	14G, 16G, 18G, 20G, 22G	Body surface
NGBC344	C344	14G, 16G, 18G, 20G, 22G	Body surface
NGBC353	C353	14G, 16G, 18G, 20G, 22G	Body surface
NGBC354	C354	14G, 16G, 18G, 20G, 22G	Body surface
NGBC611	C611	14G, 16G, 18G, 20G, 22G	Body surface
NGBC613	C613	14G, 16G, 18G, 20G, 22G	Body surface
NGBL741	L741	14G, 16G, 18G, 20G, 22G	Body surface
NGBL742	L742	14G, 16G, 18G, 20G, 22G	Body surface
NGBL752	L752	14G, 16G, 18G, 20G, 22G	Body surface
NGB2P1	2P1	14G, 16G, 18G, 20G, 22G	Body surface
NGB3C-A	3C-A	14G, 16G, 18G, 20G, 22G	Body surface
NGB4P-A	4P-A	14G, 16G, 18G, 20G, 22G	Body surface
NGB3P-A	3P-A	14G, 16G, 18G, 20G, 22G	Body surface
NGB18L-A	18L-A	14G, 16G, 18G, 20G, 22G	Body surface
NGB9L-A	9L-A	14G, 16G, 18G, 20G, 22G	Body surface
NGB13L-A	13L-A	14G, 16G, 18G, 20G, 22G	Body surface
NGB3C-B	3C-B	14G, 16G, 18G, 20G, 22G	Body surface
NGB4P-B	4P-B	14G, 16G, 18G, 20G, 22G	Body surface
NGB8V-A	8V-A	16G, 18G, 20G, 22G	Intracavity
NGB6V-A	6V-A	16G, 18G, 20G, 22G	Intracavity
NGBEC9-5	EC9-5	16G, 18G, 20G, 22G	Intracavity
NGBBCL10-5	BCL10-5	14G, 16G, 18G, 20G, 22G	Intracavity
NGBBCC9-5	BCC9-5	16G, 18G, 20G, 22G	Intracavity
NGB6V1	6V1	16G, 18G, 20G, 22G	Intracavity
NGB6V3	6V3	16G, 18G, 20G, 22G	Intracavity
NGB6V7	6V7	16G, 18G, 20G, 22G	Intracavity

14.2.2 Assembling the Biopsy Bracket

■ To Assemble the Surface Biopsy Bracket

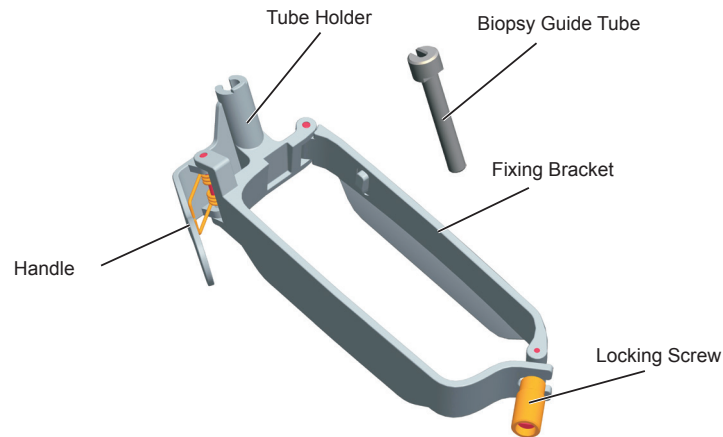

Perform the following steps.

1. Check and ensure that there is no damage, deformation, malfunction, loose or missing parts on the biopsy bracket before assembly.
2. Wear sterile gloves.
3. Unfold the probe sheath and apply an appropriate amount of coupling gel to the inside of the sheath and onto the face of the probe.
4. Hold the probe and unroll the sheath onto the probe. Pull the probe sheath tightly over the face of the probe to remove any wrinkles.
5. Align the biopsy bracket with the orientation mark of the probe.

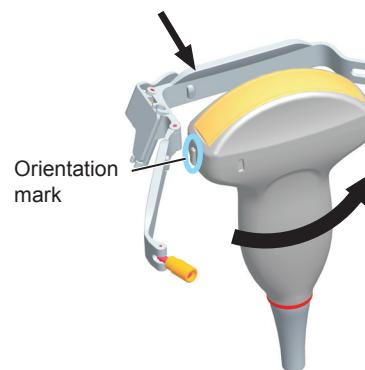

6. Attach the biopsy bracket to the probe and fasten the biopsy bracket with the locking screw.

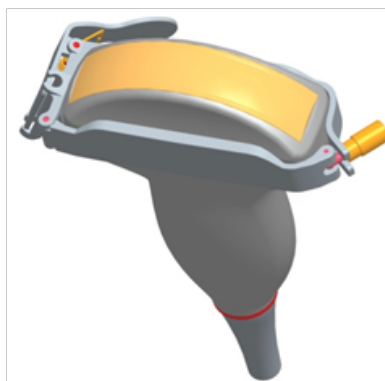

7. Press the handle and insert the biopsy bracket tube into the biopsy bracket.

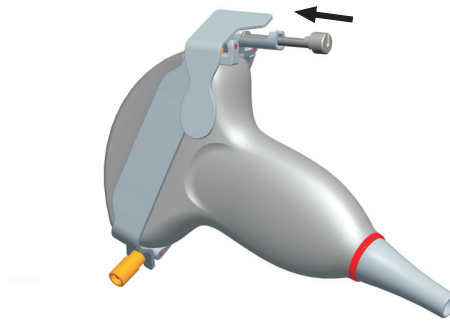

8. Insert the biopsy needle into the guide tube and make sure that the biopsy bracket is firmly attached to the probe.

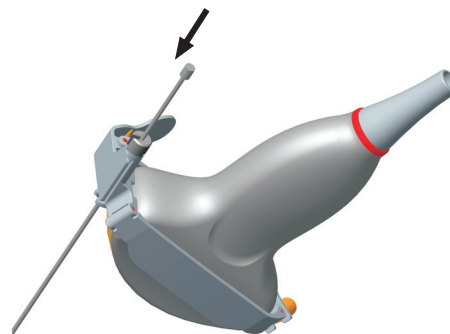

9. Unfold another probe sheath, and apply an appropriate amount of coupling gel to the inside of the sheath.
10. Hold the probe attached with the biopsy bracket and unroll the sheath onto both the probe and attached biopsy bracket.

■ **To Assemble the Endocavitary Biopsy Bracket**

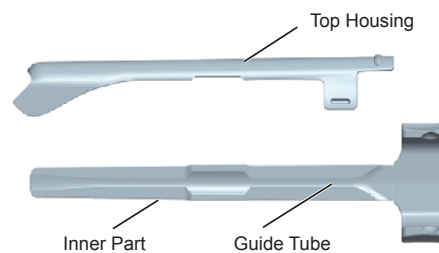

Perform the following steps.

1. Check and ensure that there is no damage, deformation, malfunction, loose or missing parts on the biopsy bracket before assembly.
2. Wear sterile gloves.
3. Unfold the probe sheath, and apply an appropriate amount of coupling gel into the sheath.
4. Hold the probe and unroll the sheath onto it. Pull the probe sheath tightly over the face of the probe to remove any wrinkles.
5. Assemble the metal top housing and the biopsy bracket. Slide the inner part into the top housing and push forward until it clicks.



6. Align the tip of the biopsy bracket with the left and right grooves on the head of the probe.
7. Hold the tip of the bracket and the head of the probe, and push the other end of the bracket towards the probe to attach it on the probe.

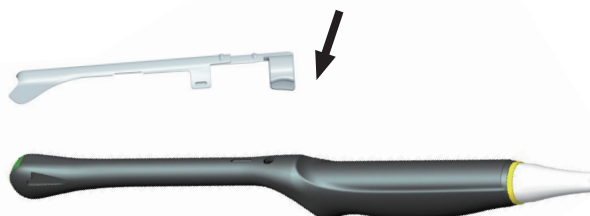

8. Insert the biopsy needle into the guide tube.
9. Check if the bracket has been firmly attached to the probe. If it is loose, reattach the biopsy bracket.
10. Unfold another probe sheath, and apply an appropriate amount of coupling gel into the sheath.
11. Hold the probe attached with the biopsy bracket, and unroll the sheath onto the probe and attached biopsy bracket.

14.2.3 Preparing for a Biopsy



WARNING Before and after using a rectal or transvaginal probe to perform a biopsy, you should clean and sterilize the probe and all the biopsy accessories. Otherwise, it may cause an infection risk to the next patient who uses the probe and accessories.

You should prepare the following items before performing the biopsy.

- New, straight, biopsy needle
- Sterilized container of sterile and degassed water
- Probe attached with biopsy needle
- Activated biopsy guidelines
- Sterile probe sheath

14.2.4 Verifying the Biopsy Bracket

NOTE:

Ensure the biopsy bracket is properly attached to the compatible probe before the verification.

Perform the following steps:

1. Tap **Biopsy** on the touch screen to in a real time scan of B-mode.
2. Immerse the probe head into the degassed water.
3. Insert the biopsy needle into the maximum depth of the water.
4. Verify that the path of the needle displays according to the guidelines shown on the image screen. After verification, the needle guide is ready for use.

14.2.5 Performing a Biopsy

NOTE:

Ensure the biopsy bracket is properly attached to the compatible probe and be verified before you perform a biopsy.

Perform the following steps:

1. Choose **Setup > General > General**, set **Guide Line Type** to **Gun** or **Needle**.
2. In the real-time B mode, tap **Biopsy** to enable the biopsy feature.
For C322, C353, 3P1 or L742 probe, you can preset the biopsy angle.
3. Perform a scan to locate the target.
4. Perform the puncture by sliding the needle through the groove in the guide until the needle, as shown on the display, intercepts the target.

You can tap **Biopsy Cali.** to adjust the biopsy guideline.

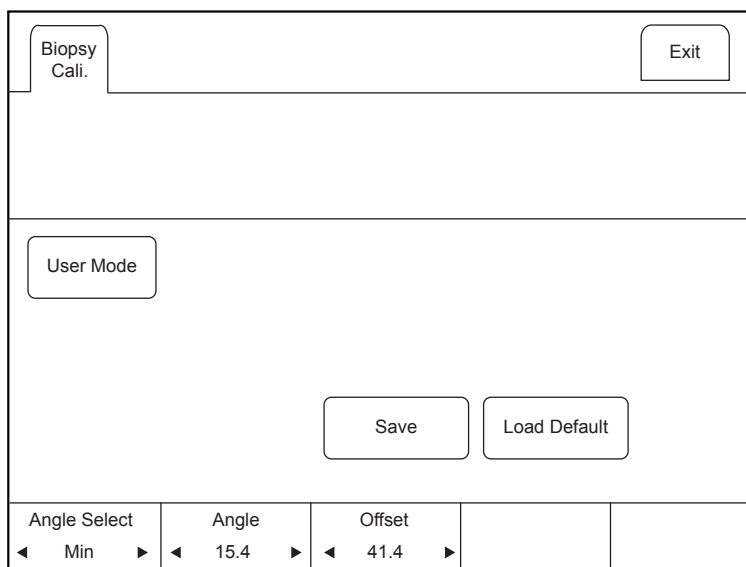

On this menu,

- For C322, C353, 3P1 or L742 probe, tap the left or right part of **Angle Select** to adjust the angle of the biopsy guideline freely.
 - Tap the left or right part of **Offset** or **Angle** to adjust the position or angle of the biopsy guideline gradually.
 - Tap **User Mode > Yes** to adjust the position and angle of the biopsy guideline freely.
 - Tap **Save** to save settings of the biopsy guideline.
 - Tap **Load Default** to restore defaults.
5. Adjust the brightness of the biopsy needle on the image.
For linear probes, you can tap **Vis-Needle** to enhance the brightness for the biopsy needle.

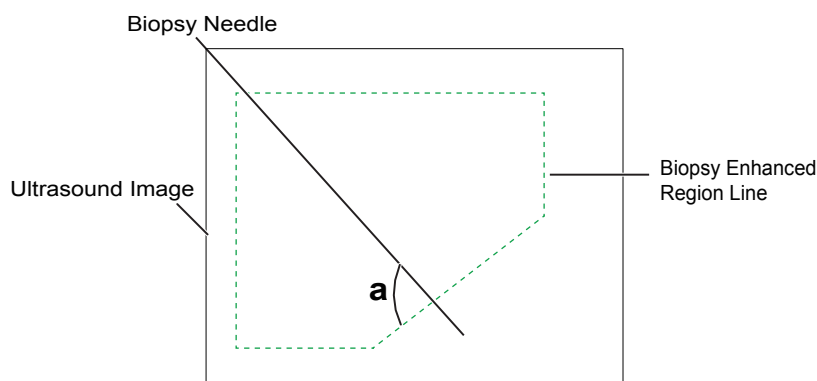

- Tap **SteerAngle** to adjust the angle of the biopsy enhanced region line. The more closely to 90° of angle a, the stronger brightness of the biopsy needle.
 - Tap **Dual Live** to enter the dual split display for better observation.
6. Gently remove the probe from the patient after completing the biopsy.

14.2.6 Cleaning the Biopsy Bracket



- Clean the biopsy bracket after each use.
- Wear medical sterile gloves and protective goggle during the cleaning.

Perform the following steps:

1. Disconnect the probe from the system, and remove the biopsy bracket and biopsy guide tube from the probe.
2. Brush and rinse the bracket with an enzymatic cleaner to remove any residue.
3. Dry the bracket with a lint-free soft dry cloth.

14.2.7 Sterilizing the Biopsy Bracket



- Disinfect the biopsy bracket after each use.
- Use the liquid sterilant that meets with local laws and regulations.
- If you use the recommended sterilant, ensure the requirements for the sterilant level and probe soaking period are met. Otherwise, the biopsy bracket could be damaged and your warranty might be void. If you have further use or needs for the probe, ensure the level of the make-up sterilant and the biopsy bracket soaking period are suitable for the intended clinical application.
- Store the biopsy bracket in a sterile environment and review its expiration date before use.
- Do not sterilize the biopsy bracket with any ethylene oxide.
- Do not allow any sterilant to be air-dried on the biopsy bracket.

Perform the following steps:

1. Clean the biopsy bracket.
 - For details, refer to Section 14.2.6 Cleaning the Biopsy Bracket.
2. Sterilize the biopsy bracket as shown in Table 14-5 until the recommended soaking period expires.
3. Rinse the bracket with the running sterile water to remove the residual sterilant completely.
4. Dry the bracket with a lint-free soft dry cloth.

Table 14-5 Recommended Method for Sterilization

Sterilant	Manufacturer	Active Ingredients	Level for Active Ingredient	Contact Type	Contact Period
Cidex™ Activated Dialdehyde Solution	J&J	Glutaraldehyde	2.4%	Soak	10 hours

14.2.8 Storage

Ensure the biopsy bracket is cleaned, sterilized and completely dried before storing it. Store the biopsy bracket in a sterile environment and keep it away from the environment of sudden temperature changes or direct sunlight.

15 System Maintenance

To maintain the safety and functionality of the system, periodically perform the maintenance for the system and accessories.



- To avoid electrical shock and damage to the system, power off and unplug the system from the AC power outlet before cleaning.
- To maintain the safety and functionality of the system, maintenance must be performed at least once every year. Electrical safety tests must also be performed at regular intervals as specified by local safety regulations.

15.1 Cleaning the System

15.1.1 To Clean the System Surface

1. Power off and unplug the system from the AC power outlet.
2. Dampen a lint-free soft cloth with 75% ethanol.
3. Use this lint-free soft cloth to clean the surfaces of the monitor screen, the touch screen, the control panel, the keyboard and the main unit. Take special care and avoid to scratch the screens.
4. Use a cotton swab to remove solids from between keys and controls.
5. In case of blood or any infectious fluids or materials, use a lint-free soft cloth dampened with 70% isopropyl alcohol.

15.1.2 To Clean the Dust Filter

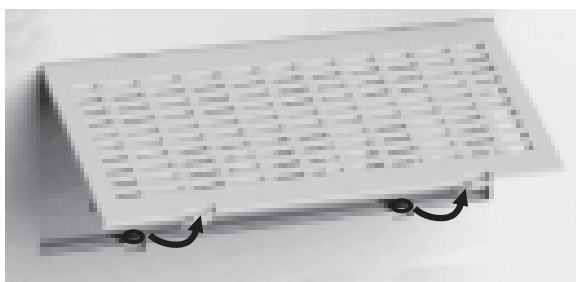

The dust filter must be cleaned at least every 3 months for ventilation.

1. Power off and unplug the system from the AC power outlet.
2. Pinch the dust filter with fingers as the figure shown above.
3. Rinse the taken out sponge with refresh running water, and use a brush to rinse the dust filter with refresh running water.
4. Place the sponge and dust filter back to the system after a thorough airing.

15.1.3 To Clean the Trackball

1. Power off and unplug the ultrasound system from the AC power outlet.
2. Press the bulges in the fixing ring by both hands.

3. Turn the fixing ring anticlockwise until the ring lifts.

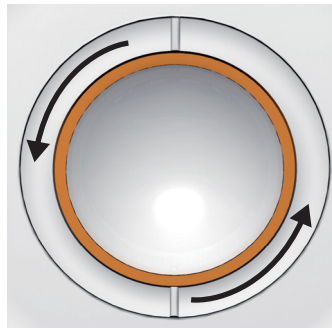

4. Take out the dust ring, the fixing ring and the ball (careful not to drop the ball) from the control panel.
5. Use a lint-free soft cloth dampened with 75% ethanol to clean the dust ring, the fixing ring and the ball.
6. Use a cotton swab dampened with 75% ethanol to remove stains from the surrounding area and edge.
7. Place the ball, the fixing ring and the dust ring back to the control panel, and turn the fixing ring clockwise to install the trackball.

15.2 Maintenance Checks

To maintain the safety and functionality of the system, the following maintenance checks must be performed by service personnel at least once every year.

- **Electric Safety**
 - Integrity of power cable
 - Protective conductor resistance
 - Ground line leakage current
 - Enclosure leakage current
 - Patient leakage current
 - Patient auxiliary leakage current

15.2.3.2 Mechanical Safety

- Appearance of the system enclosure
- Appearance of the control panel and the key panel

NOTE:

The surfaces of the control panel or the key panel may be abrasive because of the split liquid or other cleaning sprays. Check the potential problems carefully when performing maintenance checks.

- Control of foot brake
- Connectivity of interfaces

- **Image Recording**
 - Images in each mode
 - Image recording using the standard probe

15.3 Troubleshooting

Q1: Cannot start the system.

A1: Check whether the system is plugged in, the main power switch is located to **I** position and the fuse is intact. If the fuse is blown, replace it as described in Section 15.4 Replacing the Fuse.

Q2: No images are displayed on the LCD monitor.

A2: Check whether the power supply cable and video cable are securely connected.

Q3: The LCD monitor displays abnormal.

A3: Check whether you select the appropriate probe and a compatible exam type, or optimize imaging parameters correctly. For details, refer to Chapter 6 Acquiring Images.

Q4: The measurement cannot be performed after pressing the **Calc** key on the control panel.

A4: Ensure you pressing the **Calc** key in the frozen mode.

If any of the above problems still exist, please contact the Customer Service Department of the manufacturer for help.

15.4 Replacing the Fuse



Power off the system and disconnect the power cable from the socket before replacing the fuse.

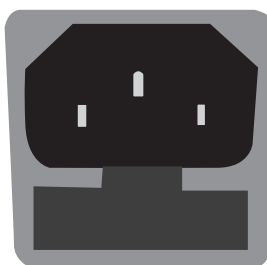

Two fuses with specifications of 50CT-T3.15AH 250V are provided by the manufacturer. You can also purchase the fuse with the same specifications for the fuse replacement.

You can replace the fuse under the instructions of the service personnel if the fuse is blown.

If the fuse is blown again after a replacement, please stop using the system immediately and contact customer service.

15.5 Equipment Disposal

You should dispose of the main unit, the probe, the biopsy bracket and other accessories in accordance with local laws and regulations.

For the detailed disposal information, consult the manufacturer or the local distributor. The manufacturer is not responsible for any system content or accessories that have been discarded improperly.

15.6 Customer Service

Only the service personnel of or authorized by the manufacturer can service the system. Any feedback or inquires concerning our product or services should be directed to the following address.

Contact Address: 2F, 12th Building, Shenzhen Software Park Phase II, Keji Middle 2nd Road, Nanshan District, Shenzhen, 518057, Guangdong, China

Tel: +86-755-26722890

E-mail: service@sonoscape.net

Appendix A Specifications

Comply with	<p>EN 60601-1 (IEC 60601-1), Medical electrical equipment Part 1: General requirements for basic safety and essential performance, Class I, BF, continuous operation</p> <p>EN 60601-2-37 (IEC 60601-2-37), Medical Electrical Equipment Part 2-37: Particular Requirements for the Basic Safety and Essential Performance of Ultrasonic Medical Diagnostic and Monitoring Equipment</p> <p>EN 60601-1-2 (IEC 60601-1-2), Medical electrical equipment- Part 1-2: General requirements for basic safety and essential performance - Collateral standard: Electromagnetic compatibility - Requirements and tests</p>		
Classifications	Type of protection against electrical shock	Class I	
	Degree of protection against electrical shock	Type-BF applied part	
	Installation Type	Mobile equipment	
	Degrees of protection against harmful liquid	<p>System is IPX0</p> <p>Probe (from the acoustic window to the junction line) is IPX7</p> <p>Foot switch is IPX4</p>	
	According to the degree of safety of application	The equipment is not suitable for use in the presence of a flammable anesthetic mixture with air, oxygen or nitrous oxide.	
Environmental Requirement		Operations	Storage and Transportation
	Ambient Temperature	10°C~40°C	-20°C~+55°C
	Relative Humidity	30%~75% (no condensation)	20%~90% (no condensation)
	Atmospheric Pressure	700hPa~1060hPa	700hPa~1060hPa
Power Supply	100-240V~, 2.7-1.1A, 50/60Hz		
Fuse	<p>Type: 50CT</p> <p>Breaking capacity: 1500 amperes at 250V AC</p> <p>Blowing time rating: 30 minutes (Max.)</p> <p>Current rating: 3.15A</p>		
Applied Parts	Probes, ECG electrodes		

Appendix B EMC Guidance and Manufacturer's Declaration

B.1 Electromagnetic Emissions

The equipment is intended for use in the electromagnetic environment specified below. The customer or the user of the EQUIPMENT should assure that it is used in such an environment.

Emissions Test	Compliance	Electromagnetic Environment and Guidance
RF emissions CISPR 11	Group 1	The equipment uses RF energy only for its internal function. Therefore, its RF emissions are very low and are not likely to cause any interference in nearby electronic equipment.
RF emissions CISPR 11	Class B	The equipment is suitable for use in all establishments, including domestic establishments and those directly connected to the public low-voltage power supply network that supplies buildings used for domestic purposes.
Harmonic emissions IEC 61000-3-2	Class A	
Voltage fluctuations/ flicker emissions IEC 61000-3-3	Complies	

B.2 Electromagnetic Immunity

The equipment is intended for use in the electromagnetic environment specified below. The customer or the user of the equipment should assure that it is used in such an environment.

Immunity Test	IEC 60601 Test Level	Compliance Level	Electromagnetic Environment and Guidance
Electrostatic discharge (ESD) IEC 61000-4-2	±6 kV Contact ±8 kV Air	±6 kV Contact ±8 kV Air	Floors should be wood, concrete or ceramic tile. If floors are covered with synthetic material, the relative humidity should be at least 30%.
Electrical fast transient/burst IEC 61000-4-4	±2 kV for power supply lines; ±1 kV for input/output lines	±2 kV for power supply lines; ±1 kV for input/output lines	Mains power quality should be that of a typical commercial or hospital environment.
Surge IEC 61000-4-5	±1 kV line to line ±2 kV line to earth	±1 kV line to line ±2 kV line to earth	Mains power quality should be that of a typical commercial or hospital environment.

<p>Voltage dips and Short interruptions IEC 61000-4-11</p>	<p><5 % U_T (>95 % dip in U_T) for 0.5 period 40 % U_T (60 % dip in U_T) for 5 periods 70 % U_T (30 % dip in U_T) for 25 periods <5 % U_T (>95 % dip in U_T) for 250 periods</p>	<p><5 % U_T (>95 % dip in U_T) for 0.5 period 40 % U_T (60 % dip in U_T) for 5 periods 70 % U_T (30 % dip in U_T) for 25 periods <5 % U_T (>95 % dip in U_T) for 250 periods</p>	<p>Mains power quality should be that of a typical commercial or hospital environment. If the user of the equipment requires continued operation during power mains interruptions, it is recommended for the equipment to be powered from an uninterruptible power supply.</p>
<p>Power frequency (50/60Hz) magnetic field IEC 61000-4-8</p>	<p>3 A/m</p>	<p>3 A/m</p>	<p>Power frequency magnetic fields should be at levels characteristic of a typical location in a typical commercial or hospital environment.</p>

NOTE: U_T is the a.c. mains voltage prior to application of the test level.

The equipment is intended for use in the electromagnetic environment specified below. The customer or the user of the equipment should assure that it is used in such an environment.

Immunity Test	IEC 60601 Test Level	Compliance Level	Electromagnetic Environment and Guidance
Conducted RF IEC 61000-4-6	3Vrms 150kHz-80 MHz	1 Vrms	Portable and mobile RF communications equipment should be used no closer to any part of the EQUIPMENT, including cables, than the recommended separation distance calculated from the equation applicable to the frequency of the transmitter. Recommended separation distance: $d = 3.5 \sqrt{P}$ $d = 1.2 \sqrt{P} \quad 80\text{MHz}-800 \text{ MHz}$ $d = 2.3 \sqrt{P} \quad 80 \text{ MHz}-2.5\text{GHz}$ Where P is the maximum output power rating of the transmitter in watts (W) according to the transmitter manufacturer and d is the recommended separation distance in meters (m). Field strengths from fixed RF transmitters, as determined by an electromagnetic site survey, ^a should be less than the compliance level in each frequency range. ^b Interference may occur in the vicinity of equipment marked with the following symbol: 
Radiated RF IEC 61000-4-3	3V/m 80 MHz-2.5GHz	3 Vrms	

NOTE 1: At 80 MHz and 800 MHz, the higher frequency range applies.

NOTE 2: These guidelines may not apply in all situations. Electromagnetic propagation is affected by absorption and reflection from structures, objects and people.

^a Field strengths from fixed transmitters, such as base stations for radio (cellular/cordless) tele- phones and land mobile radios, amateur radio, AM and FM radio broadcast and TV broadcast cannot be predicted theoretically with accuracy. To assess the electromagnetic environment due to fixed RF transmitters, an electromagnetic site survey should be considered. If the measured field strength in the location in which the EQUIPMENT is used exceeds the applicable RF compliance level above, the EQUIPMENT should be observed to verify normal operation. If abnormal performance is observed, additional measures may be necessary, such as re-orienting or relocating the EQUIPMENT.

^b Over the frequency range 150 kHz to 80 MHz, field strengths should be less than 3 V/m.

B.3 Recommended Separation Distances between Portable and Mobile RF Communications Equipment and the Equipment

The equipment is intended for use in an electromagnetic environment in which radiated RF disturbances are controlled. The customer or the user of the equipment can help prevent electromagnetic interference by maintaining a minimum distance between portable and mobile RF communications equipment (transmitters) and the equipment as recommended below, according to the maximum output power of the communications equipment.

Rated Maximum Output Power of Transmitter (W)	Separation distance according to frequency of transmitter (m)		
	150 kHz to 80 MHz $d = 1.2\sqrt{p}$	80 MHz to 800 MHz $d = 1.2\sqrt{p}$	800 MHz to 2.5 GHz $d = 2.3\sqrt{p}$
0.01	0.12	0.12	0.23
0.1	0.38	0.38	0.73
1	1.2	1.2	2.3
10	3.8	3.8	7.3
100	12	12	23

For transmitters rated at a maximum output power not listed above, the recommended separation distance d in meters (m) can be estimated using the equation applicable to the frequency of the transmitter, where P is the maximum output power rating of the transmitter in watts (W) according to the transmitter manufacturer.

NOTE 1: At 80 MHz and 800 MHz, the separation distance for the higher frequency range applies.

NOTE 2: These guidelines may not apply in all situations. Electromagnetic propagation is affected by absorption and reflection from structures, objects and people

Appendix C In Situ, Derated, and Water Value Intensities

All intensity parameters are measured in water. Since water absorbs very little acoustic energy, these water measurements represent a worst case value. Biological tissue does absorb acoustic energy. The true value of the intensity at any point depends on the amount and type of tissue and the frequency of the ultra-sound that passes through the tissue. The intensity value in the tissue, In Situ, has been estimated by using the following formula:

$$\text{In Situ} = \text{Water}[e^{-0.23alf}]$$

where: In Situ = In Situ Intensity Value

Water = Water Value Intensity

$e = 2.7183$

$a = \text{Attenuation Factor}$

Tissue = a (dB/cm-MHz)

Amniotic Fluid = 0.006

Brain = 0.53

Heart = 0.66

Kidney = 0.79

Liver = 0.43

Muscle = 0.55

$l = \text{Skin line to measurement depth (cm)}$

$f = \text{Center frequency of the transducer/system/mode combination (MHz)}$

Since the ultrasonic path during an examination is likely to pass through varying lengths and types of tissue, it is difficult to estimate the true In Situ intensity. An attenuation factor of 0.3 is used for general reporting purposes; therefore, the In Situ value which is commonly reported uses the formula:

$$\text{In Situ derated} = \text{Water}[e^{-0.069lf}]$$

Since this value is not the true In Situ intensity, the term “derated” is used.

Appendix D Recommended Coupling Gel, Cleaner and Disinfectant

NOTE:

- This appendix contains the latest information about the recommended coupling gels, cleaners and disinfectants when the user manual is released. The appendix is subject to change without prior notice.
- Some of the probe models listed in the following tables can be used with this system. For details, refer to Section 14.1.1 Available Probes.

D.1 Coupling Gel

Probe Model	Applicable	Inapplicable
MPTEE Mini 7-4, MPTEE 7-4, MPTEE, MPTEE mini, 12C-ER	Aquasonic 100, Aquasonic Clear, Sterile Aquasonic, Clear Image/Single, Sterile Ultraphonic Gel	Transonic gel, Clear Scanning Gel, Multigel Gel
LAP7, C9-5, 10I2, 6CI-A, 6CT-A, 7LI4, 10I3, 10L-I, 12L-I, 12LI-A, 12LT-A, 11L-I	Aquasonic 100, Aquasonic Clear, Sterile Aquasonic, Clear Image/Single, Sterile Ultraphonic Gel, Transonic gel	Clear Scanning Gel, Multigel Gel
EC2, EC9-5, 5V1, 6V1, 6V3, 6V4, 6V5, BCC9-4, BCC9-5, BCL10-5, 6V-A, 6V1A, 6V2A, 6V3A, 6V7, 8V-A, 6CT4	Aquasonic 100, Aquasonic Clear, Sterile Aquasonic, Clear Image/Single, Sterile Ultraphonic Gel, Transonic gel, Clear Scanning Gel	Multigel Gel
VC6-2, VC8-3, VC311, VE9-5, VL12-5, CWD2.0, CWD4.0, CWD5.0, CWD8.0, PWD2.0	Aquasonic 100, Aquasonic Clear, Sterile Aquasonic, Clear Image/Single, Sterile Ultraphonic Gel, Transonic gel	Clear Scanning Gel, Multigel Gel
2P1, 5P1, 10L1, C311, C321, C343, C344, C351, C352, C361, C362, C511, C521, C541, C542, C543, C611, C612, C721, L541, L561V, L662V, L741, L741V, L742, L743, L745, L746, L751, L752, L761V, L744, C312, C322, C345, C353, C354, C544, C613, C5-1, 3C-A, C1-6, 2P2, 3P1, 3P-A, 4P-A, 4P-B, 5P2, 7P-A, 7P-B, 8P1, 12P-A, 12P-B, P5-1, 3C-B, 9L-A, 13L-A, 18L-A, LAP7, S1-5, 12L-A	Aquasonic 100, Aquasonic Clear, Sterile Aquasonic, Clear Image/Single, Sterile Ultraphonic Gel, Transonic gel, Clear Scanning Gel, Multigel Gel	-

D.2 Cleaner

Probe Model	Applicable	Inapplicable
MPTEE Mini 7-4, MPTEE 7-4, MPTEE, MPTEE mini, 12C-ER	Mild soapy water	T-spray, T-spray II, Transeptic, 70% IPA
LAP7, C9-5, 10I2, 6CI-A, 6CT-A, 7LI4, 10I3, 10L-I, 12L-I, 12LI-A, 12LT-A, 11L-I	T-spray, T-spray II, mild soapy water	Transeptic, 70% IPA
EC2, EC9-5, 5V1, 6V1, 6V3, 6V4, 6V5, BCC9-4, BCC9-5, BCL10-5, 6V-A, 6V1A, 6V2A, 6V3A, 6V7, 8V-A, 6CT4	T-spray, T-spray II, mild soapy water	Transeptic, 70% IPA,
VC6-2, VC8-3, VC311, VE9-5, VL12-5, CWD2.0, CWD4.0, CWD5.0, CWD8.0, PWD2.0	T-spray, T-spray II, mild soapy water	Transeptic, 70% IPA
2P1, 5P1, 10L1, C311, C321, C343, C344, C351, C352, C361, C362, C511, C521, C541, C542, C543, C611, C612, C721, L541, L561V, L662V, L741, L741V, L742, L743, L745, L746, L751, L752, L761V, L744, C312, C322, C345, C353, C354, C544, C613, C5-1, 3C-A, C1-6, 2P2, 3P1, 3P-A, 4P-A, 4P-B, 5P2, 7P-A, 7P-B, 8P1, 12P-A, 12P-B, P5-1, 3C-B, 9L-A, 13L-A, 18L-A, LAP7, S1-5, 12L-A	T-spray, T-spray II, mild soapy water, 70% IPA	Transeptic

D.3 Disinfectant

Probe Model	Applicable	Inapplicable
MPTEE Mini 7-4, MPTEE 7-4, MPTEE, MPTEE mini, 12C-ER	Cidex OPA Solution, Cidex, Metricide 14	Metricide 28, Metricide 30, Resert XL HLD
LAP7, C9-5, 10I2, 6CI-A, 6CT-A, 7LI4, 10I3, 10L-I, 12L-I, 12LI-A, 12LT-A, 11L-I	Cidex OPA Solution, Cidex, Metricide 14	Metricide 28, Metricide 30, Resert XL HLD
EC2, EC9-5, 5V1, 6V1, 6V3, 6V4, 6V5, BCC9-4, BCC9-5, BCL10-5, 6V-A, 6V1A, 6V2A, 6V3A, 6V7, 8V-A, 6CT4	Cidex OPA Solution, Cidex, Metricide 14, Resert XL HLD	Metricide 28, Metricide 30
VC6-2, VC8-3, VC311, VE9-5, VL12-5, CWD2.0, CWD4.0, CWD5.0, CWD8.0, PWD2.0	Cidex OPA Solution, Cidex, Metricide 14	Metricide 28, Metricide 30, Resert XL HLD
2P1, 5P1, 10L1, C311, C321, C343, C344, C351, C352, C361, C362, C511, C521, C541, C542, C543, C611, C612, C721, L541, L561V, L662V, L741, L741V, L742, L743, L745, L746, L751, L752, L761V, L744, C312, C322, C345, C353, C354, C544, C613, C5-1, 3C-A, C1-6, 2P2, 3P1, 3P-A, 4P-A, 4P-B, 5P2, 7P-A, 7P-B, 8P1, 12P-A, 12P-B, P5-1, 3C-B, 9L-A, 13L-A, 18L-A, LAP7, S1-5, 12L-A	Cidex OPA Solution, Cidex, Metricide 14, Resert XL HLD	Metricide 28, Metricide 30

Appendix E Acoustic Output Data

Please refer to Section 4.11.2 Acoustic Output.

